

# JVC

# SERVICE MANUAL

## CD RECEIVER

# KD-SX650

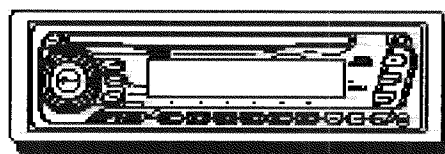
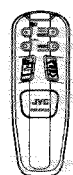

### Area Suffix

J ---- Northern America

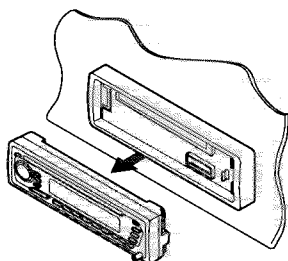

COMPACT  
**disc**  
DIGITAL AUDIO

## Contents

Safety precaution .....	1-2	Block diagram .....	2-23
Instructions .....	1-3~15	Standard schematic diagrams .....	2-25
Disassembly method .....	2-1	Printed circuit boards .....	2-28
Adjustment method .....	2-7	Parts list .....	3-1~11
Description of major ICs .....	2-11		

## Safety precaution

 **CAUTION** Burrs formed during molding may be left over on some parts of the chassis. Therefore, pay attention to such burrs in the case of performing repair of this system.

 **CAUTION** Please use enough caution not to see the beam directly or touch it in case of an adjustment or operation check.

# Instructions

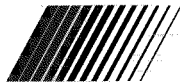

CD RECEIVER **KD-SX650**

RECEPTOR CON CD **KD-SX650**

RECEPTEUR CD **KD-SX650**

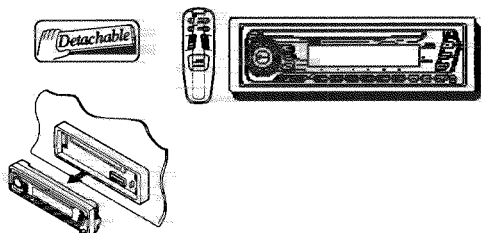

For installation and connections, refer to the separate manual.  
Para la instalación y las conexiones, refiérase al manual separado.  
Pour l'installation et les raccordements, se référer au manuel séparé.



**For customer Use:**  
Enter below the Model No. and Serial No. which are located on the top or bottom of the cabinet. Retain this information for future reference.

Model No. \_\_\_\_\_  
Serial No. \_\_\_\_\_

FSUN3103-631 [J]



## INSTRUCTIONS MANUAL DE INSTRUCCIONES MANUEL D'INSTRUCTIONS

Thank you for purchasing a JVC product. Please read all instructions carefully before operation, to ensure your complete understanding and to obtain the best possible performance from the unit.

### CONTENTS

<b>BASIC OPERATIONS</b> .....	<b>4</b>
<b>RADIO OPERATIONS</b> .....	<b>5</b>
Listening to the radio.....	5
Storing stations in memory.....	6
FM station automatic preset: SSM.....	6
Manual preset.....	7
Tuning into a preset station.....	8
<b>Other convenient tuner functions</b> .....	<b>9</b>
Scanning broadcast stations.....	9
Selecting FM reception sound.....	9
Changing the AM/FM channel intervals.....	9
<b>CD OPERATIONS</b> .....	<b>10</b>
Playing a CD.....	10
Locating a track or a particular portion a CD.....	11
Selecting CD playback modes.....	12
<b>Other convenient CD functions</b> .....	<b>12</b>
Prohibiting CD ejection.....	12
<b>SOUND ADJUSTMENTS</b> .....	<b>13</b>
Adjusting the sound.....	13
Turning on/off the loudness function.....	14
Using the Sound Control Memory.....	15
Selecting and storing the sound modes.....	15
Recalling the sound modes.....	16
Cancelling Advanced SCM.....	17
Storing your own sound adjustments.....	18
<b>OTHER MAIN FUNCTIONS</b> .....	<b>19</b>
Setting the clock.....	19
Selecting the level display.....	21
Detaching the control panel.....	22
<b>REMOTE OPERATIONS</b> .....	<b>23</b>
Installing the batteries.....	23
Using the remote controller.....	23
<b>CD CHANGER OPERATIONS</b> .....	<b>24</b>
Playing CDs.....	24
Selecting CD playback modes.....	26
<b>EXTERNAL COMPONENT OPERATIONS</b> .....	<b>27</b>
Selecting the external component to use.....	28
<b>MAINTENANCE</b> .....	<b>29</b>
Handling CDs.....	29
<b>TROUBLESHOOTING</b> .....	<b>30</b>
<b>SPECIFICATIONS</b> .....	<b>31</b>

ENGLISH  
ENGLISH

**INFORMATION (For USA)**  
This equipment has been tested and found to comply with the limits for a Class B digital device, pursuant to Part 15 of the FCC Rules. These limits are designed to provide reasonable protection against harmful interference in a residential installation. This equipment generates, uses, and can radiate radio frequency energy and, if not installed and used in accordance with the instructions, may cause harmful interference to radio communications. However, there is no guarantee that interference will not occur in a particular installation. If this equipment does cause harmful interference to radio or television reception, which can be determined by turning the equipment off and on, the user is encouraged to try to correct the interference by one or more of the following measures:  
— Reorient or relocate the receiving antenna.  
— Increase the separation between the equipment and receiver.  
— Connect the equipment into an outlet on a circuit different from that to which the receiver is connected.  
— Consult the dealer or an experienced radio/TV technician for help.

### IMPORTANT FOR LASER PRODUCTS

- Precautions:**
- CLASS 1 LASER PRODUCT**
  - DANGER:** Invisible laser radiation when open and interlock failed or defeated. Avoid direct exposure to beam.
  - CAUTION:** Do not open the top cover. There are no user-serviceable parts inside. Leave all servicing to qualified service personnel.
  - CAUTION:** This CD player uses invisible laser radiation, however, is equipped with safety switches to prevent radiation emission when unloading CDs. It is dangerous to defeat the safety switches.
  - CAUTION:** Use of controls, adjustments or performance of procedures other than those specified herein may result in hazardous radiation exposure.

### How to reset your unit

Press and hold both the SEL (Select) and  $\odot$ /I/ATT (Standby/On/ATT) buttons at the same time for several seconds.

This will reset the built-in microcomputer.

**NOTES:** Your preset adjustments — such as preset channels or sound adjustments — will also be erased.

If a CD is in the unit, it will eject when you reset the unit. Pay attention not to drop the CD.

$\odot$ /I/ATT (Standby/On/ATT)

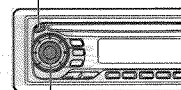

SEL (Select)

### BEFORE USE

- For safety.....
- Do not raise the volume level too much, as this will block outside sounds, making driving dangerous.
- Stop the car before performing any complicated operations.....
- Temperature inside the car.....
- If you have parked the car for a long time in hot or cold weather, wait until the temperature in the car becomes normal before operating the unit.

## BASIC OPERATIONS

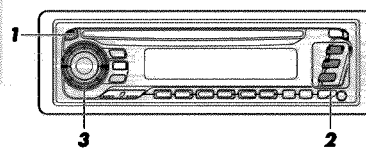

**Note:**  
When you use this unit for the first time, set the built-in clock correctly, see page 19.

**1** Turn on the power.



#### Note on One-Touch Operation:

When you select a source in step 2 below, the power automatically comes on. You do not have to press this button to turn on the power.

**2** Select the source.

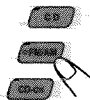

To operate the tuner, see pages 5 – 9.  
To operate the CD player, see pages 10 – 12.  
To operate the CD changer, see pages 24 – 26.  
To operate the external component, see pages 27 – 28.

**3** Adjust the volume.

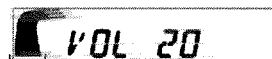
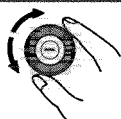

Volume level indicator. Volume level appears

**4** Adjust the sound as you want (see pages 13 – 18).

### To drop the volume in a moment

Press  $\odot$ /I/ATT briefly while listening to any source. "ATT" starts flashing on the display, and the volume level will drop in a moment.

To resume the previous volume level, press the button briefly again.

### To turn off the power

Press  $\odot$ /I/ATT for more than 1 second.

**RADIO OPERATIONS**

**Listening to the radio**

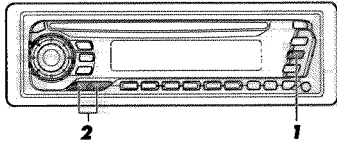

**1** Select the band (FM1, FM2, FM3 or AM).  
You can select any one of FM1, FM2, and FM3 to listen to an FM station.

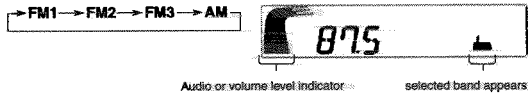

**2** Start searching a station.  
When a station is received, searching stops.

To search stations of higher frequencies.

To search stations of lower frequencies.

To stop searching before a station is received, press the same button you have pressed for searching.

**To tune in a particular frequency without searching:**

- 1 Select the band (FM or AM). Press FM/AM repeatedly.
- 2 Press and hold ▲▶▶ or ◀◀▼ until "M" starts flashing on the display. Now you can manually change the frequency while "M" is flashing.
- 3 Press ▲▶▶ or ◀◀▼ repeatedly until the frequency you want is reached.
  - If you hold down the button, the frequency keeps changing until you release the button.

ENGLISH ENGLISH

**Storing stations in memory**

You can use one of the following two methods to store broadcasting stations in memory.

- Automatic preset of FM stations: SSM (Strong-station Sequential Memory)
- Manual preset of both FM and AM stations

**FM station automatic preset: SSM**

You can preset 6 local FM stations in each FM band (FM1, FM2, and FM3).

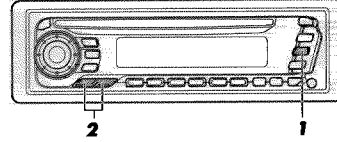

**1** Select the FM band number (FM1, FM2 or FM3) you want to store FM stations into.

**2** Press and hold the both buttons for more than 2 seconds.

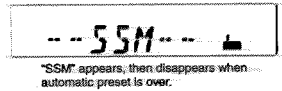

Local FM stations with the strongest signals are searched and stored automatically in the band number you have selected (FM1, FM2 or FM3). These stations are preset in the number buttons No. 1 (lowest frequency) to No. 6 (highest frequency).  
When automatic preset is over, the station stored in number button 1 will be automatically tuned in.

5 6

**Manual preset**

You can preset up to 6 stations in each band (FM1, FM2, FM3 and AM) manually.

EXAMPLE: Storing an FM station of 88.3 MHz into the preset number 1 of the FM1 band.

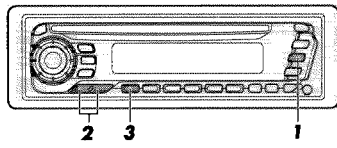

**1** Select the FM1 band.

**2** Tune into a station of 88.3 MHz.  
See page 5 to tune into a station.

**3** Press and hold the button for more than 2 seconds.

"P1" flashes for a few seconds.

**4** Repeat the above procedure to store other stations into other preset numbers.

**Notes:**

- A previously preset station is erased when a new station is stored in the same preset number.
- Preset stations are erased when the power supply to the memory circuit is interrupted (for example, during battery replacement). If this occurs, preset the stations again.

ENGLISH ENGLISH

**Tuning into a preset station**

You can easily tune into a preset station.  
Remember that you must store stations first. If you have not stored them yet, see pages 6 and 7.

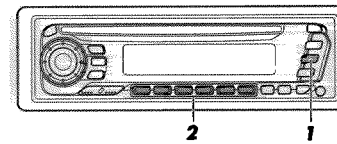

**1** Select the band (FM1, FM2, FM3 or AM) you want.

**2** Select the number (1 - 6) for the preset station you want.

7 8

**CD OPERATIONS**

**Other convenient tuner functions**

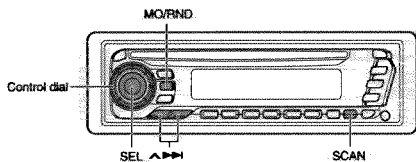

**Scanning broadcast stations**

When you press SCAN while listening to the radio, station scanning starts. Each time a broadcast is tuned in, scanning stops for about 5 seconds (tuned frequency number flashes on the display), and you can check what program is now being broadcasted.

If you want to listen to that program, press the same button again to stop scanning.

**Selecting FM reception sound**

When an FM stereo broadcast is hard to receive: Press MO/RND (Mono/Random) while listening to an FM stereo broadcast. The sound you hear becomes monaural but reception will be improved.



Lights up when receiving an FM broadcast in stereo. To restore the stereo effect, press the same button again.

**Changing the AM/FM channel intervals**

When using this unit in an area other than North or South America: When this unit is shipped from the factory, the channel intervals are set to 10 kHz for AM and 200 kHz for FM. You can change the channel intervals by following the procedure below.

- 1 Press SEL (select) for more than 2 seconds. "CLOCK H," "CLOCK M," "SCM LINK," "LEVEL," "AREA" or "LINE IN" appears on the display.
  - \* Displayed only when one of the following sources is selected — FM, AM and CD.
- 2 If "AREA" does not appear, press ▲▶▶ or ◀◀▼ until it appears.
- 3 Rotate the control dial clockwise. "AREA EU" appears and the channel intervals are set to 9 kHz for AM and 50 kHz (for manual tuning) / 100 kHz (for searching) for FM.

To reset to the factory setting, follow the above step 1 and 2, then rotate the control dial counterclockwise in step 3 ("AREA US" appears on the display).

- AREA EU: Select this when used in an area other than North and South America.
- AREA US: Select this when used in North or South America.

**Playing a CD**

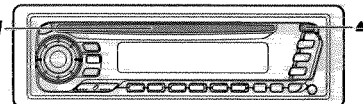

1



Insert a disc into the loading slot. The unit turns on, draws a CD and starts playback automatically.
 

- When a CD is inserted upside down, "EJECT" appears on the display and the CD automatically ejects.

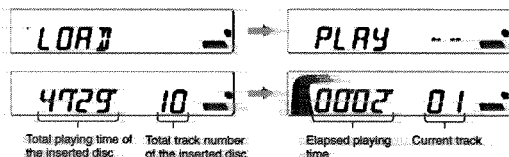

Total playing time of the inserted disc    Total track number of the inserted disc    Elapsed playing time    Current track

**Note on One-Touch Operation:** When a CD is already in the loading slot, pressing CD turns on the unit and starts playback automatically.

**CAUTION on Volume Setting:** CDs produce very little noise compared with other sources. If the volume level is adjusted for the tuner, for example, the speakers may be damaged by the sudden increase in the output level. Therefore, lower the volume before playing a CD and adjust it as required during playback.

**To stop play and eject the CD**

Press ▲. CD play stops and the CD automatically ejects from the loading slot. The source changes to the tuner (you will hear the last received station). If you change the source to FM/AM or CD-CH, the CD play also stops (without ejecting the CD this time).
 

- If the ejected disc is not removed for about 15 seconds, the disc is automatically inserted again into the loading slot to protect it from dust. (CD play will not start this time.)
- You can eject the CD even when the unit is turned off.

**Locating a track or a particular portion on a CD**

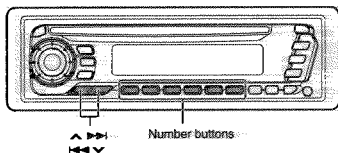

**To fast forward or reverse the track**



Press and hold ▲▶▶, while playing a CD, to fast forward the track. Press and hold ◀◀▼, while playing a CD, to reverse the track.

**To go to the next track or the previous track**

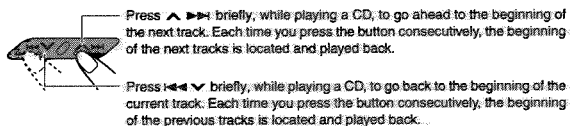

Press ▲▶▶ briefly, while playing a CD, to go ahead to the beginning of the next track. Each time you press the button consecutively, the beginning of the next tracks is located and played back. Press ◀◀▼ briefly, while playing a CD, to go back to the beginning of the current track. Each time you press the button consecutively, the beginning of the previous tracks is located and played back.

**To go to a particular track directly**



Press the number button corresponding to the track number to start its playback.
 

- To select a track number from 1 – 6: Press 1 (7) – 6 (12) briefly.
- To select a track number from 7 – 12: Press and hold 1 (7) – 6 (12) for more than 1 second.

**Selecting CD playback modes**

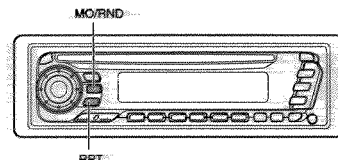

**To play back tracks at random (Random Play)**

You can play back all tracks on the CD at random. Each time you press MO/RND (Mono/Random) while playing a CD, CD random play mode turns on and off alternatively. When the random mode is turned on, the RND indicator lights up on the display and a track randomly selected starts playing.



**To play back tracks repeatedly (Repeat Play)**

You can play back the current track repeatedly. Each time you press RPT (Repeat) while playing a CD, CD repeat play mode turns on and off alternatively. When the repeat mode is turned on, the RPT indicator lights up on the display.



Track number of the currently playing track

**Other convenient CD functions**

**Prohibiting CD ejection**

You can prohibit the CD ejection and can "lock" a CD in the loading slot. Press and hold CD and ▲ for more than 2 seconds. "EJECT" flashes on the display for about 5 seconds, and the CD is "locked." To cancel the prohibition and "unlock" the CD, press and hold CD and ▲ for more than 2 seconds again. "EJECT" appears on the display, and the CD ejects from the loading slot.

## SOUND ADJUSTMENTS

### Adjusting the sound

You can adjust the treble/bass sound and the speaker balance.

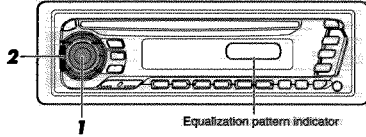

1 Select the item you want to adjust.  
 → BAS → TRE → FAD → BAL → VOL

Indication	To do:	Range
BAS (Bass)	Adjust the bass	-6 (min.) — +6 (max.)
TRE (Treble)	Adjust the treble	-6 (min.) — +6 (max.)
FAD (Fader)*	Adjust the front and rear speaker balance	R6 (rear only) — F6 (front only)
BAL (Balance)	Adjust the left and right speaker balance	L6 (left only) — R6 (right only)
VOL (Volume)	Adjust the volume	00 (min.) — 50 (max.)

Note:  
 \* If you are using a two-speaker system, set the fader level to "00."

2 Adjust the level.  
 Equalization pattern changes as you adjust the bass or treble.

Note:  
 Normally the control dial works as the volume control. So you do not have to select "VOL" to adjust the volume level.

ENGLISH

### Turning on/off the loudness function

The human ear is less sensitive to low and high frequencies at low volumes. The loudness function can boost these frequencies to produce well-balanced sound at low volume level. Each time you press LOUD, the loudness function turns on and off alternatively.



13 14

### Using the Sound Control Memory

You can select and store a preset sound adjustment suitable to each playback source. (Advanced SCM)

#### Selecting and storing the sound modes

Once you select a sound mode, it is stored in memory, and will be recalled every time you select the same source. A sound mode can be stored each of the following sources — FM1, FM2, FM3, AM, CD, CD changer and external components.

• If you do not want to store the sound mode separately for each playback source, but want to use the same sound mode for all the sources, see "Canceling Advanced SCM" on page 17.

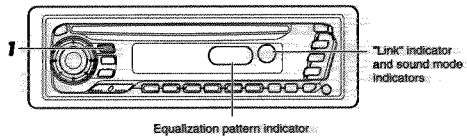

1 Select the sound mode you want.  
 Each time you press the button, the sound mode changes as follows.  
 → SCM OFF → BEAT → SOFT → POP

- If the "Link" indicator is lit on the display (with "SCM LINK" set to "LINK ON" — see page 17), the selected sound mode can be stored in memory for the current source, and the effect applies to the current source.
- If the "Link" indicator is NOT lit on the display (with "SCM LINK" set to "LINK OFF"), the selected sound mode effect applies to any source.

Indication	For:	Preset values		
		Bass	Treble	Loudness
SCM OFF	(Flat sound)	00	00	On
BEAT	Rock or disco music	+2	00	On
SOFT	Quiet background music	+1	-3	Off
POP	Light music	+4	+1	Off

ENGLISH

### Recalling the sound modes



1 Select the source while the "Link" indicator is lit on the display.  
 The "Link" indicator starts flashing, and the sound mode stored in memory for the selected source is recalled.  
 Equalization pattern of the selected sound mode appears.

- Notes:
- You can adjust each sound mode to your preference, and store it in memory.
  - If you want to adjust and store your original sound mode, see "Storing your own sound adjustments" on page 18.
  - To adjust the bass and treble reinforcement levels or to turn on/off the loudness function temporarily, see pages 13 and 14. Your adjustments will be cancelled if another source is selected.

15 16

### Canceling Advanced SCM

You can cancel the Advanced SCM (Sound Control Memory), and unlink the sound modes and the playback sources.  
 When shipped from the factory, a different sound mode can be stored in memory for each source so that you can change the sound modes simply by changing the sources.  
**LINK ON:** Advanced SCM (different SCMs for different sources)  
**LINK OFF:** Conventional SCM (one SCM for all sources)

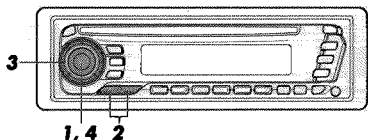

- 1** Press and hold SEL for more than 2 seconds. "CLOCK H," "CLOCK M," "SCM LINK," "LEVEL," "AREA" or "LINE IN" appears on the display.  
\* Displayed only when one of the following sources is selected: FM, AM and CD.
- 2** Select "SCM LINK" if not shown on the display.
- 3** Select the desired mode — "LINK ON" or "LINK OFF".
- 4** Finish the setting.

### Storing your own sound adjustments

You can adjust the sound modes (BEAT, SOFT, POP; see page 15) to your preference and store your own adjustments in memory.

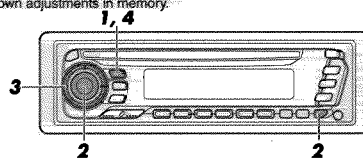

- 1** Call up the sound mode you want to adjust. See page 15 for details.
- 2** To adjust the bass or treble sound level. Select "BAS" or "TRE."  
 To turn on or off the loudness function. Each time you press LOUD, the loudness function turns on and off alternatively. (→ go to step 4).
- 3** Adjust the bass or treble level. See page 13 for details.
- 4** Press and hold SCM until the sound mode you have selected in step 1 flashes on the display. Your setting is stored in memory.
- 5** Repeat the same procedure to store other settings.

#### To reset to the factory settings

Repeat the same procedure and reassign the preset values listed in the table on page 15.

### OTHER MAIN FUNCTIONS

#### Setting the clock

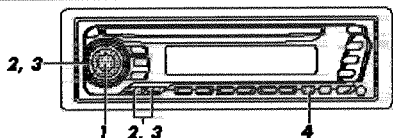

- 1** Press and hold SEL for more than 2 seconds. "CLOCK H," "CLOCK M," "SCM LINK," "LEVEL," "AREA" or "LINE IN" appears on the display.  
\* Displayed only when one of the following sources is selected: FM, AM and CD.
- 2** Set the hour.  
 1. Select "CLOCK H" if not shown on the display.  
  
 2. Adjust the hour.
- 3** Set the minute.  
 1. Select "CLOCK M."  
  
 2. Adjust the minute.
- 4** Start the clock.

#### To check the current clock time (changing the display mode)

Press DISP repeatedly. Each time you press the button, the display mode changes as follows.

<b>During tuner operation:</b> 	<b>During CD operation:</b> 
<b>During CD changer operation:</b> 	<b>During external component operation:</b> 

\* If the unit is not in use when you press DISP, the power turns on, the clock time is shown for 5 seconds, then the power turns off.

**Selecting the level display**

You can select the level display according to your preference. When shipped from the factory, "AUDIO 2" is selected.  
**AUDIO1:** Shows the audio level indicator and the equalization pattern indicator.  
**AUDIO2:** Alternates "AUDIO 1" setting and illumination display.  
**OFF:** Erases the audio level indicator and the equalization pattern indicator.

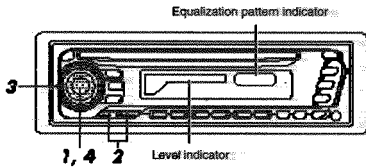

- 1** Press and hold SEL for more than 2 seconds. "CLOCK H," "CLOCK M," "SCM LINK," "LEVEL," "AREA" or "LINE IN" appears on the display.  
\* Displayed only when one of the following sources is selected—FM, AM and CD.
- 2** Select "LEVEL" if not shown on the display.
- 3** Select the desired mode—"AUDIO1", AUDIO2" or "OFF".
- 4** Finish the setting.

**Detaching the control panel**

You can detach the control panel when leaving the car. When detaching or attaching the control panel, be careful not to damage the connectors on the back of the control panel and on the panel holder.

**How to detach the control panel**

Before detaching the control panel, be sure to turn off the power.

- 1** Unlock the control panel.

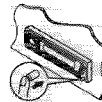

- 2** Lift and pull the control panel out of the unit.

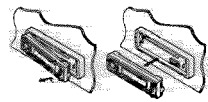

- 3** Put the detached control panel into the case provided.

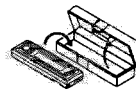

**How to attach the control panel**

- 1** Insert the left side of the control panel into the groove on the panel holder.

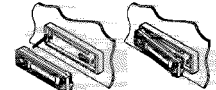

- 2** Press the right side of the control panel to fix it to the panel holder.



**Note on cleaning the connectors:**  
 If you frequently detach the control panel, the connectors will deteriorate. To minimize this possibility, periodically wipe the connectors with a cotton swab or cloth moistened with alcohol, being careful not to damage the connectors.

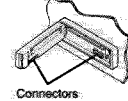

**REMOTE OPERATIONS**

- Before using the remote controller:**
- Aim the remote controller directly at the remote sensor on the main unit. Make sure there is no obstacle in between.
  - Do not expose the remote sensor to strong light (direct sunlight or artificial lighting).

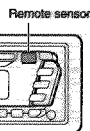

**Installing the batteries**

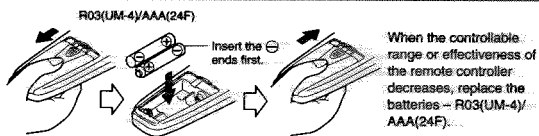

**Using the remote controller**

- 
- 1** Functions the same as the **0/1/ATT** button on the main unit.
  - 2** Select the source. Each time you press **FUNC** (function), the source changes.
  - 3** Functions the same as the control dial on the main unit.
  - 4** Functions as the **BAND** button while listening to the radio. Each time you press the button, the band changes.
    - Functions as the **DISC +** button while listening to the CD changer. Each time you press the button, the disc number increases, and selected disc starts playing.
    - Does not function as the **PROG** button.
  - 5** Functions as the **PRESET** button while listening to the radio. Each time you press the button, the preset station number increases, and selected station is tuned in.
    - Functions as the **DISC -** button while listening to the CD changer. Each time you press the button, the disc number decreases, and selected disc starts playing.
  - 6** Searches stations while listening to the radio.
    - Fast forwards or reverses the track if pressed and held while listening to the CD.
    - Skips to the beginning of the next tracks or go back to the beginning of the current (or previous tracks) if pressed briefly while listening to the CD.

**Note:**  
 These buttons cannot be used for the clock (CLOCK H, CLOCK M), SCM LINK, LEVEL, FM/AM channel intervals (AREA) and LINE IN adjustments (see pages 19, 17, 21, 9 and 28).

**CD CHANGER OPERATIONS**

We recommend that you use one of the CH-X series with your unit. If you have another CD automatic changer, consult your JVC car audio dealer for connections. For example, if your CD automatic changer is one of the KD-MK series, you need a cord (KS-U1SK) for connecting it to this unit.

- Before operating your CD automatic changer:**
- Refer also to the instructions supplied with your CD changer.
  - If no discs are in the magazine of the CD changer or the discs are inserted upside down, "NO CD" or "NO DISC" will appear on the display. If this happens, remove the magazine and set the discs correctly.
  - If "RESET 1" - "RESET 6" appears on the display, something is wrong with the connection between this unit and the CD changer. If this happens, check the connection, connect the connecting cord(s) firmly if necessary, then press the reset button of the CD changer.

**Playing CDs**

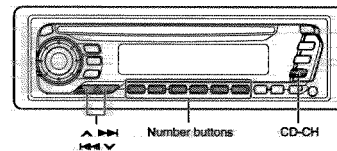

Select the CD automatic changer. Play back starts from the first track of the first disc. All tracks of all discs are played back.

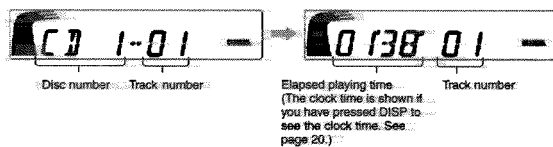

**Note on One-Touch Operation:**  
 When you press CD-CH, the power automatically comes on. You do not have to press 0/1/ATT to turn on the power.



**To fast forward or reverse the track.**

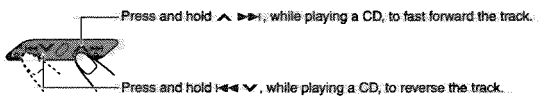

**To go to the next track or the previous track.**

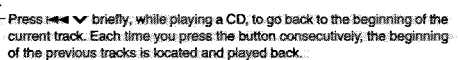
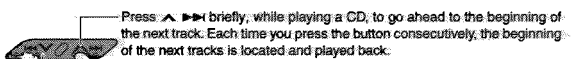

**To go to a particular disc directly**

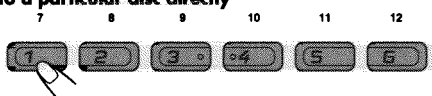

Press the number button corresponding to the disc number to start its playback (while the CD changer is playing).

- To select a disc number from 1 – 6: Press 1 (7) – 6 (12) briefly.
- To select a disc number from 7 – 12: Press and hold 1 (7) – 6 (12) for more than 1 second.

Ex. When disc number 1 is selected

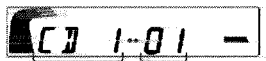

Disc number: Track number

ENGLISH ENGLISH

**Selecting CD playback modes**

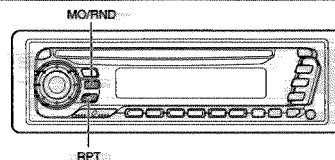

**To play back tracks at random (Random Play)**

Each time you press MO/RND (Mono/Random) while playing a CD, CD random play mode changes as follows:



Mode	RND indicator	Plays at random
RND1	Lights	All tracks of the current disc, then the tracks of the next disc, and so on.
RND2	Flashes	All tracks of all discs inserted in the magazine.

**To play back tracks repeatedly (Repeat Play)**

Each time you press RPT (Repeat) while playing a CD, CD repeat play mode changes as follows:



Mode	RPT indicator	Plays repeatedly
RPT1	Lights	The current track (or specified track).
RPT2	Flashes	All tracks of the current disc (or specified disc).

25 26

**EXTERNAL COMPONENT OPERATIONS**

You can connect the external component to the CD changer jack on the rear using the Line Input Adaptor KS-U57 (not supplied).

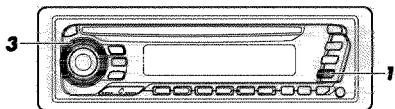

**Preparations:**

- For connecting the Line Input Adaptor KS-U57 and the external component, refer to the Installation/Connection Manual (separate volume).
- Before operating the external component using the following procedure, select the external input correctly. (See "Selecting the external component to use" on page 28.)

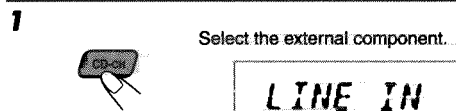

- If "LINE IN" does not appear on the display, see page 28 and select the external input ("LINE IN").

**Note on One-Touch Operation:**  
When you press CD-CH, the power automatically comes on. You do not have to press ON/OFF to turn on the power.

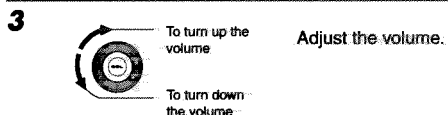

ENGLISH ENGLISH

**Selecting the external component to use**

You can connect the external component to the CD changer jack on the rear using the Line Input Adaptor KS-U57 (not supplied).

To use the external component as the playback source through this receiver, you need to select which device — CD changer or external component — to use. When shipped from the factory, CD changer is selected as the external component.

- LINE IN: To use the external component other than CD changer.
- CHANGER: To use the CD changer.

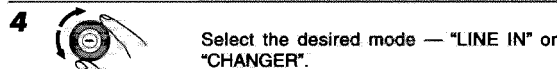
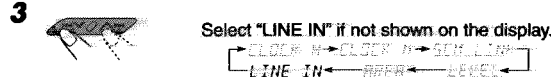
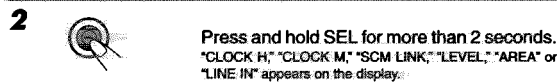
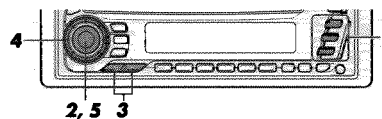

**Note:**  
For connecting the Line Input Adaptor KS-U57 and the external component, refer to the Installation/Connection Manual (separate volume).

27 28

**MAINTENANCE ?!**

**Handling CDs**

This unit has been designed only to reproduce the CDs bearing the  mark. Other discs cannot be played back.

**How to handle CDs**

**When removing a CD from its case**, press down the center holder of the case and lift the CD out, holding it by the edges.

- Always hold the CD by the edges. Do not touch its recording surface.

**When storing a CD into its case**, gently insert the CD around the center holder (with the printed surface facing up).

- Make sure to store CDs into the cases after use.

**To keep CDs clean**

A dirty CD may not play correctly. If a CD does become dirty, wipe it with a soft cloth in a straight line from center to edge.

**To play new CDs**

New CDs may have some rough spots around the inner and outer edges. If such a CD is used, this unit may reject the CD. To remove these rough spots, rub the edges with a pencil or ball-point pen, etc.

**Moisture condensation**

Moisture may condense on the lens inside the CD player in the following cases:

- After starting the heater in the car.
- If it becomes very humid inside the car.

Should this occur, the CD player may malfunction. In this case, eject the CD and leave the unit turned on for a few hours until the moisture evaporates.

Center holder



**CAUTIONS:**

- Do not insert 8cm (3 1/16") CDs (single CDs) into the loading slot. (Such CDs cannot be ejected.)
- Do not insert any CD of unusual shape—like a heart or flower; otherwise, it will cause a malfunction.
- Do not expose CDs to direct sunlight or any heat source or place them in a place subject to high temperature and humidity. Do not leave them in a car.
- Do not use any solvent (for example, conventional record cleaner, spray, thinner, benzine, etc.) to clean CDs.

**When playing a CD-R (Recordable)**

You can play back your original CD-Rs on this receiver.

- Before playing back CD-Rs, read their instructions or cautions carefully.
- Some CD-Rs recorded on CD recorders may not be played back on this receiver because of their disc characteristics, and of the following reasons:
  - Discs are dirty or scratched.
  - Moisture condensation occurs on the lens inside the unit.
  - The pickup lens inside the CD player is dirty.
- Use only "finalized" CD-Rs.
- CD-RWs (Rewritable) cannot be played back on this receiver.

**About mistracking:**

Mistracking may result from driving on extremely rough roads. This does not damage the unit and the CD, but will be annoying. We recommend that you stop CD play while driving on such rough roads.

**TROUBLESHOOTING**

What appears to be trouble is not always serious. Check the following points before calling a service center.

Symptoms	Causes	Remedies
• CD cannot be played back.	CD is inserted upside down.	Insert the CD correctly.
• CD sound is sometimes interrupted.	You are driving on rough roads.	Stop CD play while driving rough roads.
	CD is scratched.	Change the CD.
• Sound cannot be heard from the speakers.	Connections are incorrect.	Check the cords and connections.
	The volume is turned to the minimum level.	Adjust it to the optimum level.
• SSM (Strong-station Sequential Memory) automatic preset does not work.	Signals are too weak.	Store stations manually.
	Connections are incorrect.	Check the cords and connections.
• Static noise while listening to the radio.	The antenna is not connected firmly.	Connect the antenna firmly.
	• "NO CD" or "NO DISC" appears on the display.	No CD is in the loading slot (or in the magazine).
• "RESET 0" appears on the display.	CD is inserted incorrectly.	Insert it correctly.
	This unit is not connected to a CD changer correctly.	Connect this unit and the CD changer correctly.
• "RESET 1-RESET 7" appears on the display.		Press the reset button of the CD changer.
• CD can be neither played back nor ejected.	The CD player may function incorrectly.	Press <b>0</b> /HATT and <b>A</b> at the same time for more than 2 seconds. Be careful not to drop CD when it is ejected.
• The unit does not work at all.	The built-in microcomputer may function incorrectly due to noise, etc.	Press <b>0</b> /HATT and SEL at the same time for more than 2 seconds to reset the unit. (The clock setting and preset stations stored in memory are erased.) (See page 2.)

**SPECIFICATIONS**

**AUDIO AMPLIFIER SECTION**

Maximum Power Output:  
 Front: 40 watts per channel  
 Rear: 40 watts per channel  
 Continuous Power Output (RMS):  
 Front: 16 watts per channel into 4 Ω, 40 to 20,000 Hz at no more than 0.8% total harmonic distortion.  
 Rear: 16 watts per channel into 4 Ω, 40 to 20,000 Hz at no more than 0.8% total harmonic distortion.  
 Load Impedance: 4 Ω (4 to 8 Ω allowance)  
 Tone Control Range  
 Bass: ±10 dB at 100 Hz  
 Treble: ±10 dB at 10 kHz  
 Frequency Response: 40 to 20,000 Hz  
 Signal-to-Noise Ratio: 70 dB  
 Line-Out Level/Impedance: 2.0 V/20 kΩ load (full scale)  
 Output Impedance: 1 kΩ

**TUNER SECTION**

Frequency Range  
 FM: 87.5 to 107.9 MHz  
 (with channel interval set to 200 kHz)  
 87.5 to 108.0 MHz  
 (with channel interval set to 50 kHz)  
 AM: 530 to 1,710 kHz  
 (with channel interval set to 10 kHz)  
 531 to 1,602 kHz  
 (with channel interval set to 9 kHz)

**FM Tuner**

Usable Sensitivity: 11.3 dBf (1.0 μV/75 Ω)  
 50 dB Quieting Sensitivity:  
 16.3 dBf (1.8 μV/75 Ω)  
 Alternate Channel Selectivity (400 kHz):  
 65 dB  
 Frequency Response: 40 to 15,000 Hz  
 Stereo Separation: 35 dB  
 Capture Ratio: 1.5 dB

**AM Tuner**

Sensitivity: 20 μV  
 Selectivity: 35 dB

**CD PLAYER SECTION**

Type: Compact disc player  
 Signal Detection System: Non-contact optical pickup (semiconductor laser)  
 Number of channels: 2 channels (stereo)  
 Frequency Response: 5 to 20,000 Hz  
 Dynamic Range: 96 dB  
 Signal-to-Noise Ratio: 98 dB  
 Wow and Flutter: Less than measurable limit

**GENERAL**

Power Requirement:  
 Operating Voltage: DC 14.4 volts (11 to 16 volts allowance)  
 Allowable Working Temperature:  
 0°C to +40°C (32°F to 104°F)  
 Grounding System: Negative ground  
 Dimensions (W x H x D):  
 Installation Size:  
 182 x 52 x 150 mm  
 (7-3/16" x 2-1/16" x 5-15/16")  
 Panel Size: 188 x 58 x 14 mm  
 (7-7/16" x 2-5/16" x 5/8")  
 Mass: 1.3 kg (2.9 lbs) (excluding accessories)  
 Design and specifications subject to change without notice.

If a kit is necessary for your car, consult your telephone directory for the nearest car audio specialty shop.

**Having TROUBLE with operation?**  
**Please reset your unit**  
 Refer to page of How to reset  
**Still having trouble??**

USA ONLY

**Call 1-800-252-5722**

<http://www.jvcservice.com>

**We can help you!**





**Installation/Connection Manual**  
**Manual de instalación/conexión**  
**Manuel d'installation/raccordement**

FSUN3103-T631  
 [J]

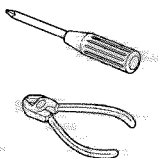

1099HISFLEJES  
 EN, SP, FR

**ENGLISH**

**ESPAÑOL**

**FRANÇAIS**

This unit is designed to operate on 12 volts DC, NEGATIVE ground electrical systems.

Esta unidad está diseñada para funcionar con 12 voltios de CC, con sistemas eléctricos de masa NEGATIVA.

Cet appareil est conçu pour fonctionner sur des sources de courant continu de 12 volts à masse NEGATIVE.

**INSTALLATION (IN-DASH MOUNTING)**

**INSTALACION (MONTAJE EN EL TABLERO DE INSTRUMENTOS)**

**INSTALLATION (MONTAGE DANS LE TABLEAU DE BORD)**

The following illustration shows a typical installation. However, you should make adjustments corresponding to your specific car. If you have any questions or require information regarding installation kits, consult your JVC car audio dealer or a company supplying kits.

La siguiente ilustración muestra una instalación típica. Sin embargo usted deberá efectuar los ajustes correspondientes a su automóvil. Si tiene alguna pregunta o necesita información acerca de las herramientas para instalación, consulte con su concesionario de JVC o de equipos de audio para automóviles o a una compañía que suministra tales herramientas.

L'illustration suivante est un exemple d'installation typique. Cependant, vous devez faire les ajustements correspondant à votre voiture particulière. Si vous avez des questions ou avez besoin d'information sur des kits d'installation, consultez votre revendeur d'autoradios JVC ou une compagnie d'approvisionnement.

- 1 Before mounting:** Press **▲** (Control Panel Release button) to detach the control panel.
- 2 Remove the trim plate.**
- 3 Remove the sleeve after disengaging the sleeve locks:**
  - Stand the unit.
  - Note:** When you stand the unit, be careful not to damage the fuse on the rear.
  - Insert the 2 handles between the unit and the sleeve, as illustrated, to disengage the sleeve locks.
  - Note:** Be sure to keep the handles for future use after installing the unit.
- 4 Install the sleeve into the dashboard.**
  - After the sleeve is correctly installed in the dashboard, bend the appropriate tabs to hold the sleeve firmly in place, as illustrated.
- 5 Fix the mounting bolt to the rear of the unit's body and place the rubber cushion over the end of the bolt.**
- 6 Do the required electrical connections explained on the back of this instructions.**
- 7 Slide the unit into the sleeve until it is locked.**
- 8 Attach the trim plate so that the projection on the trim plate is fixed to the left side of the unit.**
- 9 Attach the control panel.**

- 1 Antes de instalar:** Presione **▲** (botón de liberación del panel de control) para desmontar el panel de control.
- 2 Retire la placa de guarnición.**
- 3 Retire la cubierta después de desenganchar los retenes de la cubierta:**
  - Ponga la unidad vertical.
  - Nota:** Al poner la unidad vertical, tenga cuidado de no dañar el fusible provisto en la parte posterior.
  - Inserte las dos asas entre la unidad y la cubierta tal como en la ilustración y desenganche los retenes de la cubierta.
  - Retire la cubierta.
  - Nota:** Después de instalar la unidad, asegúrese de guardar las asas para uso futuro.
- 4 Instale la cubierta en el tablero de instrumentos:**
  - Después de que la cubierta esté correctamente instalada en el tablero de instrumentos, doble las lengüetas correspondientes para sostener la cubierta firmemente en su lugar, tal como se muestra.
- 5 Fije el perno de montaje en la parte trasera del cuerpo de la unidad y coloque el cojin de goma sobre el extremo del perno.**
- 6 Realice las conexiones eléctricas requeridas en base a las explicaciones que figuran en la parte de atrás de estas instrucciones.**
- 7 Deslice la unidad dentro de la cubierta hasta que quede trabada.**
- 8 Coloque la placa de guarnición de manera que el saliente de la misma quede colocado en el lateral izquierdo de la unidad.**
- 9 Coloque el panel de control.**

- 1 Avant le montage:** Appuyer sur **▲** (touche de libération du panneau de commande) pour détacher le panneau de commande.
- 2 Retirer la plaque d'assemblage.**
- 3 Libérer les verrous du manchon et retirer le manchon:**
  - Poser l'appareil à la verticale.
  - Remarque:** Lorsque vous mettez l'appareil à la verticale, faire attention de ne pas endommager le fusible situé sur le fond.
  - Insérer les 2 poignées entre l'appareil et le manchon comme indiqué pour désengager les verrous de manchon.
  - Retirer le manchon.
  - Remarque:** S'assurer de garder les poignées pour une utilisation ultérieure, après l'installation de l'appareil.
- 4 Installer le manchon dans le tableau de bord:**
  - Après installation correcte du manchon dans le tableau de bord, plier les bonnes parties pour maintenir fermement le manchon en place, comme montré.
- 5 Monter le boulon de montage sur l'arrière du corps de l'appareil puis passer l'amortisseur en caoutchouc sur l'extrémité du boulon.**
- 6 Réaliser les connexions électriques expliquées au dos de cette page.**
- 7 Faire glisser l'appareil dans le manchon jusqu'à ce qu'il soit verrouillé.**
- 8 Attacher la plaque d'ajustage de façon que la projection de la plaque soit fixée sur le côté gauche de l'appareil.**
- 9 Remonter le panneau de commande.**

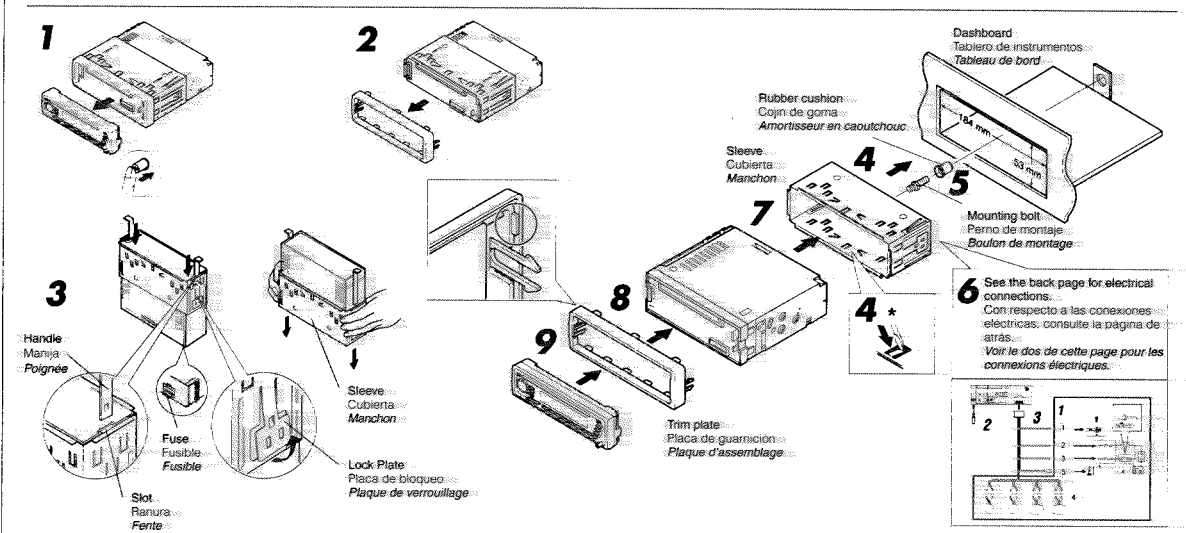

**TROUBLESHOOTING**

**LOCALIZACION DE AVERIAS**

**EN CAS DE DIFFICULTÉS**

- The fuse blows.**
  - Are the red and black leads connected correctly?
- Power cannot be turned on.**
  - Is the yellow lead connected?
- No sound from the speakers.**
  - Is the speaker output lead short-circuited?
- Sound is distorted.**
  - Is the speaker output lead grounded?
  - Are the L and R terminals of L and R speakers grounded in common?
- Unit becomes hot.**
  - Is the speaker output lead grounded?
  - Are the L and R terminals of L and R speakers grounded in common?

- El fusible se quema.**
  - ¿Están los conductores rojo y negro correctamente conectados?
- No es posible conectar la alimentación.**
  - ¿Está el cable amarillo conectado?
- No sale sonido de los altavoces.**
  - ¿Está el cable de salida del altavoz cortocircuitado?
- El sonido presenta distorsión.**
  - ¿Está el cable de salida del altavoz conectado a masa?
  - ¿Están los terminales L y R conectados a una masa común?
- La unidad se calienta.**
  - ¿Está el cable de salida del altavoz conectado a masa?
  - ¿Están los terminales L y R de los altavoces conectados a una masa común?

- Le fusible saute.**
  - Les fils rouge et noir sont-ils raccordés correctement?
- L'appareil ne peut pas être mis sous tension.**
  - Le fil jaune est-elle raccordée?
- Pas de son des haut-parleurs.**
  - Le fil de sortie de haut-parleur est-il court-circuité?
- Le son est déformé.**
  - Le fil de sortie de haut-parleur est-il à la masse?
  - Les bornes L et R des haut-parleurs gauche et droit sont-elles mises ensemble à la masse?
- L'appareil devient chaud.**
  - Le fil de sortie de haut-parleur est-il à la masse?
  - Les bornes L et R des haut-parleurs gauche et droit sont-elles mises ensemble à la masse?

- When using the optional stay
- Cuando emplea un soporte opcional
- Lors de l'utilisation du hauban en option

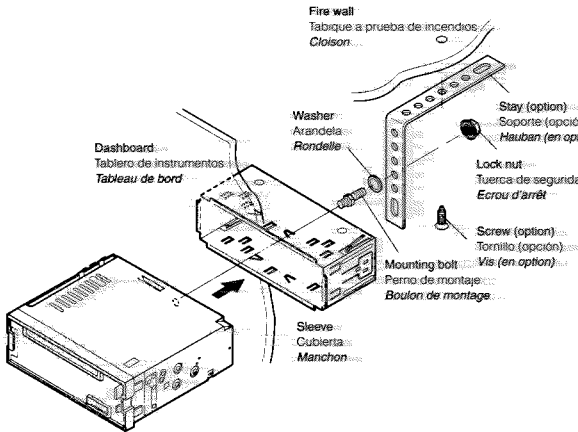

- When installing the unit without using the sleeve
- Instalación de la unidad sin utilizar la cubierta
- Lors de l'installation de l'appareil sans utiliser de manchon

In a Toyota for example, first remove the car radio and install the unit in its place.  
 En un Toyota por ejemplo, primero extraiga la radio del automóvil y luego instale la unidad en su lugar.  
 Par exemple dans une Toyota, retirer d'abord l'autoradio et installer l'appareil à la place.

- Flat type screws (M5 x 6 mm)\*
- Tornillos tipo plano (M5 x 6 mm)\*
- Vis à tête plate (M5 x 6 mm)\*

- \* Not included with this unit.
- \* No suministrado con esta unidad.
- \* Non fourni avec cet appareil.

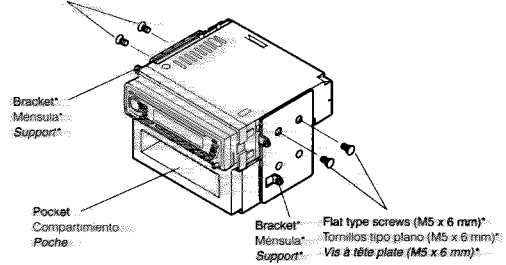

**Note:** When installing the unit on the mounting bracket, make sure to use the 6 mm-long screws. If longer screws are used, they could damage the unit.

**Nota:** Cuando instala la unidad en la ménsula de montaje, asegúrese de utilizar los tornillos de 6 mm de longitud. Si se utilizan tornillos más largos, éstos pueden dañar la unidad.

**Remarque:** Lors de l'installation de l'appareil sur le support de montage, s'assurer d'utiliser des vis d'une longueur de 6 mm. Si des vis plus longues sont utilisées, elles peuvent endommager l'appareil.

**Removing the unit**

- Before removing the unit, release the rear section.

- 1 Remove the control panel.
- 2 Remove the trim plate.
- 3 Insert the 2 handles into the slots, as shown. Then, while gently pulling the handles away from each other, slide out the unit. (Be sure to keep the handles after installing it.)

**Extracción de la unidad**

- Antes de extraer la unidad, libere la sección trasera.

- 1 Extraiga el panel de control.
- 2 Retire la placa de guarnición.
- 3 Inserte las 2 manijas entre las ranuras, como se muestra. Luego, separe gentilmente las manijas y extraiga la unidad. (Asegúrese de conservar las manijas después de instalarlo.)

**Retrait de l'appareil**

- Avant de retirer l'appareil, libérer la section arrière.

- 1 Retirer le panneau de commande.
- 2 Retirer la plaque d'assemblage.
- 3 Introduire les deux poignées dans les fentes, comme montré. Puis, tout en tirant doucement les poignées écartées, faire glisser l'appareil pour le sortir. (S'assurer de conserver les poignées après l'installation de l'appareil.)

1

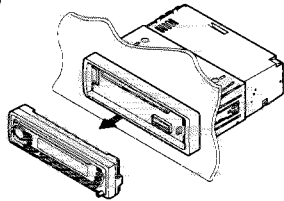

2

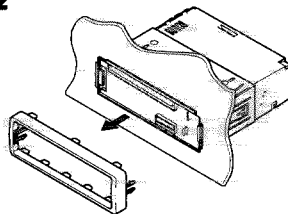

3

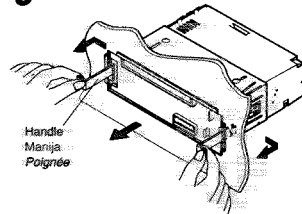

**Parts list for installation and connection**

The following parts are provided with this unit. After checking them, please set them correctly.

**Lista de piezas para instalación y conexión**

Con esta unidad se suministran las siguientes piezas. Después de inspeccionarlas, colóquelas correctamente.

**Liste des pièces pour l'installation et raccordement**

Les pièces suivantes sont fournies avec cet appareil. Après vérification, veuillez les placer correctement.

Hard case  
Estuche duro  
Etui de transport

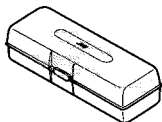

Sleeve  
Cubierta  
Manchon

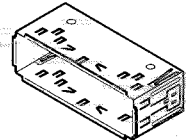

Remote controller and holder  
Mando a distancia y soporte  
Télécommande et support

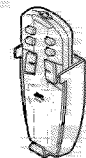

Power cord  
Cordón de alimentación  
Cordon d'alimentation

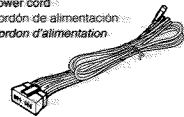

Trim plate  
Placa de guarnición  
Plaque d'assemblage

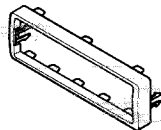

Batteries  
Pilas  
Piles



R03(UM-4)/AAA(24F)

Handles  
Manijas  
Poignées



Washer (ø5)  
Arandela (ø5)  
Rondelle (ø5)



Lock nut (M5)  
Tuerca de seguridad (M5)  
Ecrin d'arret (M5)



Mounting bolt (M5 x 20 mm)  
Perno de montaje (M5 x 20 mm)  
Boulon de montage (M5 x 20 mm)



Rubber cushion  
Cojín de goma  
Amortisseur en caoutchouc



**Installation : Remote Controller**  
**Instalación : Mando a distancia**  
**Installation : Télécommande**

Dashboard, etc.  
Tablero de instrumentos, etc.  
Tableau de bord, etc.

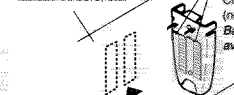

Double-faced tape (not included with this unit)  
Cinta adhesiva de ambos lados (no suministrado con esta unidad)  
Bande double face (non fourni avec cet appareil)

Holder  
Soporte  
Support

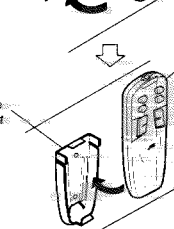

Remote controller  
Mando a distancia  
Télécommande

- Before attaching the double-faced tape, wipe and clean the place where you plan to attach it.
- Antes de adherir la cinta de doble cara, limpie el sitio de instalación con un paño.
- Avant d'attacher la bande double face, essuyez et nettoyez l'emplacement où vous projettez de l'attacher.

**ENGLISH**      **ESPAÑOL**      **FRANÇAIS**

**ELECTRICAL CONNECTIONS**      **CONEXIONES ELECTRICAS**      **RACCORDEMENTS ELECTRIQUES**

To prevent short circuits, we recommend that you disconnect the battery's negative terminal and make all electrical connections before installing the unit. If you are not sure how to install this unit correctly, have it installed by a qualified technician.

Para evitar cortocircuitos, recomendamos que desconecte el terminal negativo de la batería y que efectúe todas las conexiones eléctricas antes de instalar la unidad. Si usted no está seguro de cómo instalar correctamente la unidad, hágala instalar por un técnico cualificado.

Pour éviter tout court-circuit, nous vous recommandons de débrancher la borne négative de la batterie et d'effectuer tous les raccordements électriques avant d'installer l'appareil. Si l'on n'est pas sûr de pouvoir installer correctement cet appareil, le faire installer par un technicien qualifié.

**Note:**  
This unit is designed to operate only on 12 volts DC, NEGATIVE ground electrical systems. If your vehicle does not have this system, a voltage inverter is required, which can be purchased at JVC car audio dealers.

**Nota:**  
Esta unidad está diseñada para funcionar con 12 voltios de CC, con sistemas eléctricos de masa NEGATIVA solamente. Si su vehículo no posee este sistema, será necesario un inversor de tensión, que puede ser adquirido en los concesionarios de JVC de equipos de audio para automóviles.

**Remarque:**  
Cet appareil est conçu pour fonctionner sur des sources de courant continu de 12 volts à masse NEGATIVE seulement. Si votre véhicule n'offre pas ce type d'alimentation, il vous faut un convertisseur de tension, que vous pouvez acheter chez un revendeur d'autoradios JVC.

- Replace the fuse with one of the specified rating. If the fuse blows frequently, consult your JVC car audio dealer.
- If noise is a problem... This unit incorporates a noise filter in the power circuit. However, with some vehicles, clicking or other unwanted noise may occur. If this happens, connect the unit's rear ground terminal (See connection diagram below) to the car's chassis using shorter and thicker cords, such as copper braiding or gauge wire. If noise still persists, consult your JVC car audio dealer.
- Maximum input of the speakers should be more than 40 watts at the rear and 40 watts at the front, with an impedance of 4 to 8 ohms.
- Be sure to ground this unit to the car's chassis.
- The heat sink becomes very hot after use. Be careful not to touch it when removing this unit.

- Reemplazé el fusible por uno con la corriente especificada. Si el fusible se quemase frecuentemente, consulte con su concesionario de JVC de equipos de audio para automóviles.
- Si el ruido fue un problema... Esta unidad tiene un filtro de ruido en el circuito de alimentación. Sin embargo, en algunos vehículos, pueden producirse chasquidos u otros ruidos indeseados. En tal caso conecte el terminal de tierra posterior (Ver diagrama de conexión abajo) del receptor al chasis del automóvil, utilizando cordones más gruesos y cortos tales como alambre de cobre trenzado o de grueso calibre. Si el ruido persiste, consulte a su concesionario de JVC de equipos de audio para automóvil.
- La entrada máxima de los altavoces traseros debe ser mayor de 40 vatios y la de los delanteros de 40 vatios, con una impedancia de 4 a 8 ohmios.
- Asegúrese de conectar esta unidad a tierra en el chasis del automóvil.
- El sumidero térmico estará muy caliente después del uso. Asegúrese de no tocarlo al desmontar esta unidad.

- Remplacer le fusible par un de la valeur précisée. Si le fusible saute souvent, consulter votre revendeur d'autoradios JVC.
- Si le bruit est un problème... Cet appareil incorpore un filtre de bruit dans le circuit d'alimentation. Cependant, avec certains véhicules, quelques claquements ou autres bruits non désirés risquent de se produire. Si cela arrive, raccorder la borne de masse arrière de l'appareil au châssis de la voiture (voir le schéma de raccordement ci-dessous) en utilisant des cordons les plus gros et les plus courts possibles telle qu'une barre de cuivre ou une tresse. Si le bruit persiste, consulter votre revendeur d'autoradios JVC.
- La puissance admissible des haut-parleurs doit être supérieure à 40 watts à l'arrière et à 40 watts l'avant, avec une impédance de 4 à 8 ohms.
- S'assurez de raccorder la mise à la masse de cet appareil au châssis de la voiture.
- Le radiateur devient très chaud après usage. Faire attention de ne pas le toucher en retirant cet appareil.

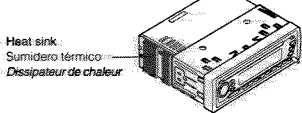

**A Typical Connections / Conexiones típicas / Raccordements typiques**

**Before connecting:** Check the wiring in the vehicle carefully not to fail in connecting this unit. Incorrect connection may cause a serious damage to this unit.

**Antes de la conexión:** Verifique atentamente el conexionado del vehículo para no cometer errores al conectar esta unidad. Una conexión incorrecta podría producir daños graves en la unidad.

**Avant de commencer la connexion:** vérifiez attentivement le câblage du véhicule pour ne pas connecter incorrectement cet appareil. Une connexion incorrecte peut endommager sérieusement l'appareil.

- 1 Connect the colored leads of the power cord to the car battery, speakers and automatic antenna (if any) in the following sequence:
  - ① Black: ground
  - ② Yellow: to car battery (constant 12V)
  - ③ Red: to an accessory terminal
  - ④ Others (except blue with white stripe): to speakers
  - ⑤ Blue with white stripe: to automatic antenna (200mA max.)
- 2 Connect the antenna cord.
- 3 Finally connect the wiring harness to the unit.

- 1 Conecte los conductores de color del cable de alimentación a la batería del automóvil, altavoces y antena automática (si la hubiera) en la secuencia siguiente:
  - ① Negro: a tierra
  - ② Amarillo: a la batería del automóvil (12V constantes)
  - ③ Rojo: a un terminal de accesorio
  - ④ Otros, excepto azul con rayas blancas: a los altavoces
  - ⑤ Azul con rayas blancas: a la antena automática (200mA máx.)
- 2 Conecte el cable de antena.
- 3 Por último, conecte a la unidad el cableado preformado.

- 1 Connectez les fils de couleur du cordon d'alimentation à la batterie de la voiture, aux enceintes et à l'antenne automatique (s'il y en a une) dans l'ordre suivant.
  - ① Noir: à la masse
  - ② Jaune: à la batterie de la voiture (12V constant)
  - ③ Rouge: à la prise accessoire
  - ④ Autres fils à l'exception du fil bleu à bandes blanches: aux enceintes
  - ⑤ Bleu à bandes blanches: à l'antenne automatique (200mA max.)
- 2 Connectez le cordon d'antenne.
- 3 Finalement, connectez le faisceau de fils à l'appareil.

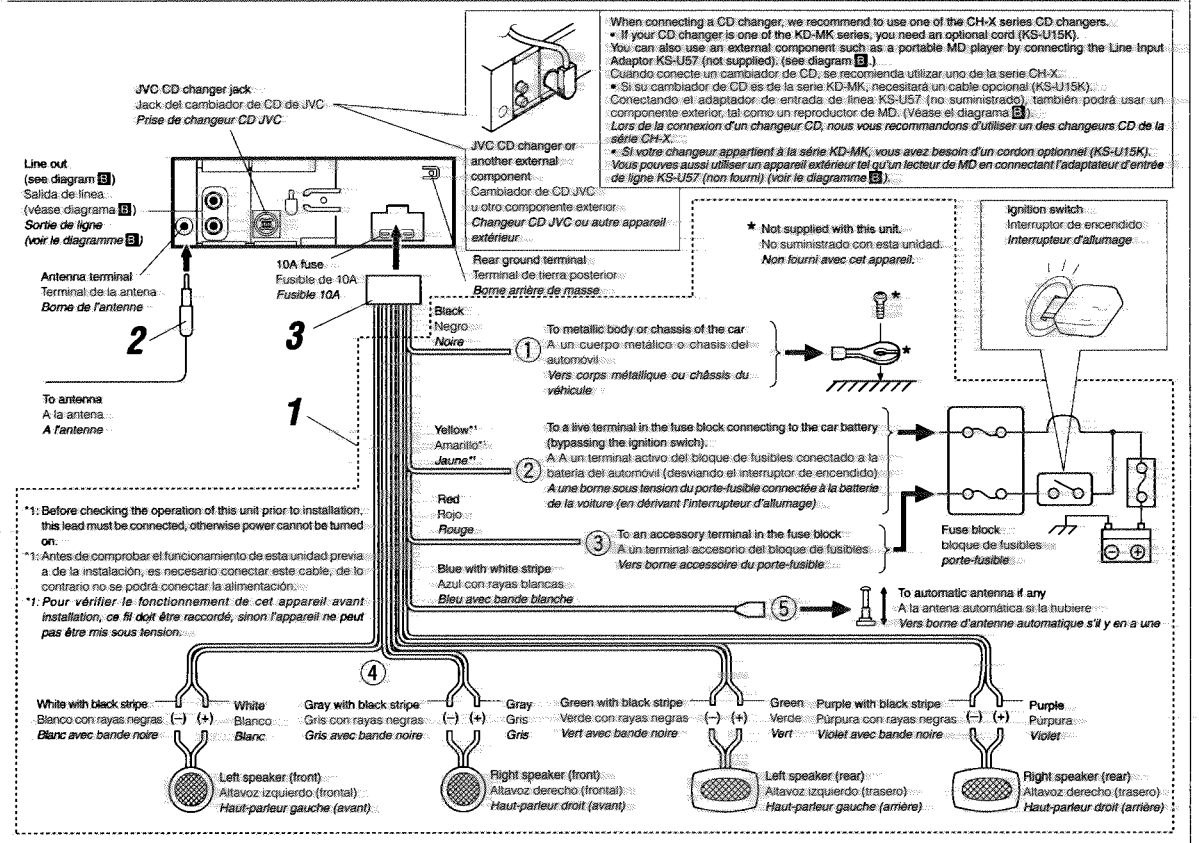

**PRECAUTIONS on power supply and speaker connections:**

- DO NOT connect the speaker leads of the power cord to the car battery; otherwise, the unit will be seriously damaged.
- Connect the black lead (ground), yellow lead (to car battery, constant 12V), and red lead (to an accessory terminal) correctly.
- BEFORE connecting the speaker leads of the power cord to the speakers, check the speaker wiring in your car.
  - If the speaker wiring in your car is as illustrated in Fig. 1 and Fig. 2 below, DO NOT connect the unit using that original speaker wiring. If you do, the unit will be seriously damaged.
  - Redo the speaker wiring so that you can connect the unit to the speakers as illustrated in Fig. 3.
  - If the speaker wiring in your car is as illustrated in Fig. 3, you can connect the unit using the original speaker wiring in your car.
  - If you are not sure of the speaker wiring of your car, consult your car dealer.

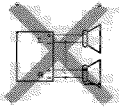

Fig. 1

**PRECAUCIONES sobre las conexiones de la fuente de alimentación y de los altavoces:**

- NO conecte los conductores de altavoz del cable de alimentación a la batería de automóvil, pues podrían producirse graves daños en la unidad.
- Conecte correctamente el conductor negro (a tierra), el conductor amarillo (a la batería del automóvil, 12V constantes) y el conductor rojo (a un terminal de accesorio).
- ANTES de conectar a los altavoces los conductores de altavoz del cable de alimentación, verifique el conexionado de altavoz de su automóvil.
  - Si el conexionado de altavoz de su automóvil es como se indica en las Figs. 1 y 2 de abajo, NO conecte la unidad utilizando ese conexionado de altavoz original. Si lo hace, se producirán daños graves en la unidad.
  - Vuelva a efectuar el conexionado de altavoz de manera que pueda conectar la unidad a los altavoces de la manera indicada en la Fig. 3.
  - Si el conexionado de altavoz de su automóvil es como se indica en la Fig. 3, podrá conectar la unidad utilizando el conexionado de altavoz original de su automóvil.
  - Si tiene dudas sobre el conexionado de altavoz de su automóvil, consulte con su concesionario.

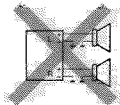

Fig. 2

**PRECAUTIONS sur l'alimentation et la connexion des enceintes:**

- NE CONNECTEZ PAS les fils d'enceintes du cordon d'alimentation à la batterie; sinon, l'appareil serait sérieusement endommagé.
- Connectez correctement le fil noir (à la masse), le fil jaune (à la batterie de la voiture, 12V constant) et le fil rouge (à la prise accessoire).
- AVANT de connecter les fils d'enceintes du cordon d'alimentation aux enceintes, vérifiez le câblage des enceintes de votre voiture.
  - Si le câblage des enceintes de votre voiture est réalisé comme montré sur la Fig. 1 ou Fig. 2 ci-dessous, NE CONNECTEZ PAS l'appareil en utilisant ce câblage original d'enceintes. Si vous le faites, l'appareil sera sérieusement endommagé.
  - Recommencez le câblage des enceintes de façon que vous puissiez connecter l'appareil aux enceintes comme montré sur la Fig. 3.
  - Si le câblage des enceintes de votre voiture est comme montré sur la Fig. 3, vous pouvez connecter l'appareil en utilisant ce câblage original d'enceintes pour votre voiture.
  - Si vous n'êtes pas sûr du câblage d'enceintes de votre voiture, consultez le concessionnaire de votre voiture.

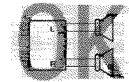
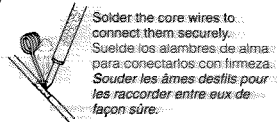

Fig. 3

**Connecting the leads / Conexión de los conductores / Raccordement des fils**

Twist the core wires when connecting.  
Retuerza los alambres de alma para conectarlos.  
Torsader les âmes des fils en les raccordant.



Solder the core wires to connect them securely.  
Suelde los alambres de alma para conectarlos con firmeza.  
Souder les âmes des fils pour les raccorder entre eux de façon sûre.

**CAUTION / PRECAUCION / PRECAUTION:**

- To prevent short-circuit, cover the terminals of the UNUSED leads with insulating tape.
- Para evitar cortocircuitos, cubra los cables NO UTILIZADOS con cinta aislante.
- Pour éviter les court-circuits, couvrir les bornes des fils qui ne sont PAS utilisés avec de la bande isolante.

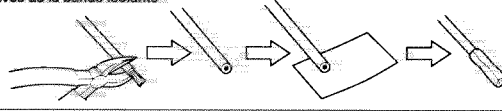

**Connections Adding Other Equipment / Conexiones para añadir otros equipos / Raccordement pour ajouter d'autres appareils**

You can connect an amplifier and other equipment to upgrade your car stereo system.

- Connect the remote lead (blue with white stripe) to the remote lead of the other equipment so that it can be controlled through this unit.
- For amplifier only:
  - Connect this unit's line-out terminals to the amplifier's line-in terminals.
  - Disconnect the speakers from this unit, connect them to the amplifier. Leave the speaker leads of this unit unused. (Cover the terminals of these unused leads with insulating tape, as illustrated above.)

Usted podrá conectar un amplificador y otros equipos para mejorar el sistema estéreo de su automóvil.

- Conecte el cable remoto (azul con rayas blancas) al cable remoto del otro equipo para que pueda ser controlado a través de esta unidad.
- Sólo para el amplificador:
  - Conecte los terminales de salida de línea de esta unidad con los terminales de entrada de línea del amplificador.
  - Desconecte los altavoces de esta unidad y conéctelos al amplificador. Los cables de los altavoces de esta unidad quedan sin usar. (Cubra los terminales de estos cables sin usar con cinta aislante, tal como se indica en la figura de arriba.)

Vous pouvez connecter un amplificateur ou autre appareil pour améliorer votre système autoradio.

- Connecter le fil d'alimentation à distance (bleu avec des bandes blanches) au fil d'alimentation à distance de l'autre appareil de façon qu'il puisse être contrôlé par cet appareil.
- Pour l'amplificateur seulement:
  - Raccorder les bornes de sortie ligne de cet appareil aux bornes d'entrée ligne de l'amplificateur.
  - Déconnectez les enceintes de cet appareil et connectez-les à l'amplificateur. Laissez les fils d'enceintes de cet appareil inutilisés. (Recouvrez les extrémités de ces fils inutilisés avec de la bande isolante comme montré ci-dessus.)

**Amplifier / Amplificador / Amplificateur**

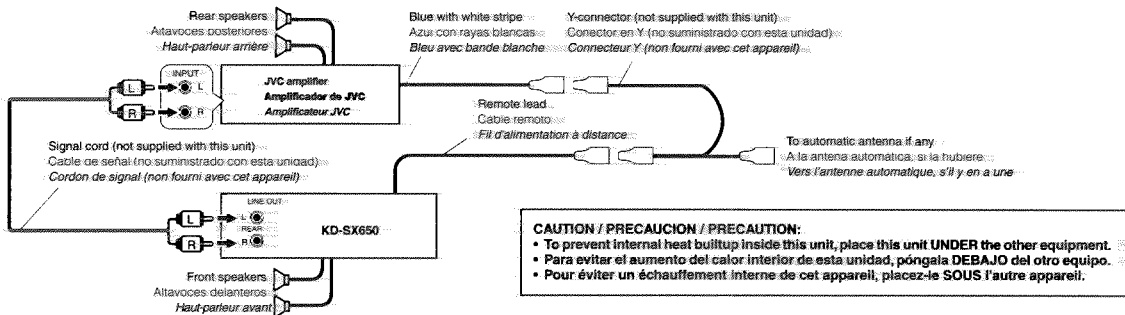

- CAUTION / PRECAUCION / PRECAUTION:**
- To prevent internal heat buildup inside this unit, place this unit UNDER the other equipment.
  - Para evitar el aumento del calor interior de esta unidad, póngala DEBAJO del otro equipo.
  - Pour éviter un échauffement interne de cet appareil, placez-le SOUS l'autre appareil.

**External component / Componente exterior / Appareil extérieur**

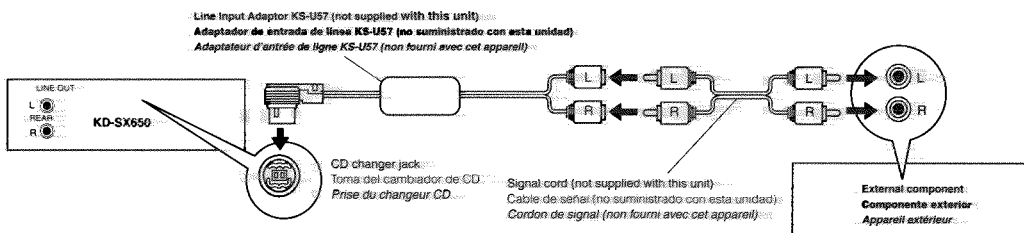

# JVC IMPORTANT

Notice the following information will help you solve your problems.  
Keep this IMPORTANT sheet together with the INSTRUCTIONS book.

- **After installing the unit.**  
→ Follow the procedure **A** described below.
- **If the unit does not operate.**  
→ Follow the procedure **A** described below.
- **If a CD is not ejected from the loading slot.**  
→ Follow the procedure **B** described below. (If the procedure **B** does not work, try the procedure **A**.)
- **If a CD is not recognized ("NO DISC" appears on the display) even though there is a CD in the loading slot.**  
→ Follow the procedure **B** described below. (If the procedure **B** does not work, try the procedure **A**.)
- **If a CD is in the unit, it will eject when you reset the unit.**  
**Pay attention not to drop the CD.**

## **A** To reset the microcomputer

Press and hold both the SELECT (SEL) and POWER/ATT(⏻/ATT) buttons at the same time for several seconds.

This will reset the built-in microcomputer.

**NOTE:** Your preset adjustments — such as preset channels or sound adjustments — will also be erased.

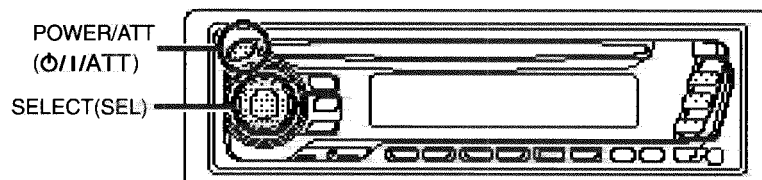

## **B** To eject a CD by force

Press and hold both the POWER/ATT(⏻/ATT) and EJECT(▲) buttons at the same time for several seconds until the CD is ejected from the loading slot.

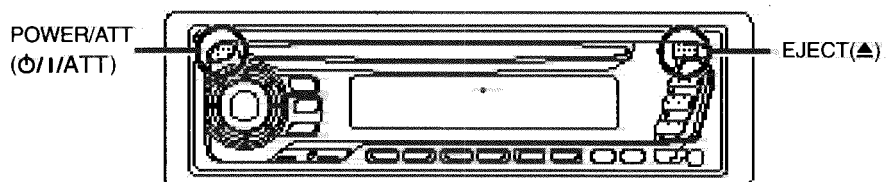

FSUD3103-001A

KD-SX650

<<MEMO>>



## Disassembly method

### ■ Removing the front panel unit

(See Fig.1)

1. Press the release switch on the front side of the body and remove the front panel unit in the direction of the arrow.

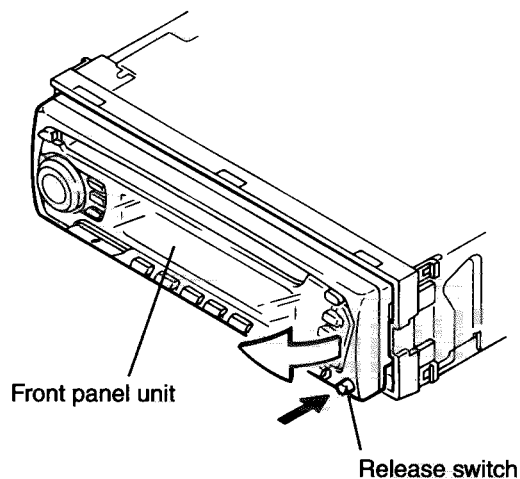

Fig.1

### ■ Removing the front chassis (See Fig.2)

1. Insert a screwdriver to the two joints a on the left side of the front chassis and two joints b on the right side, then detach the front chassis toward the front side.

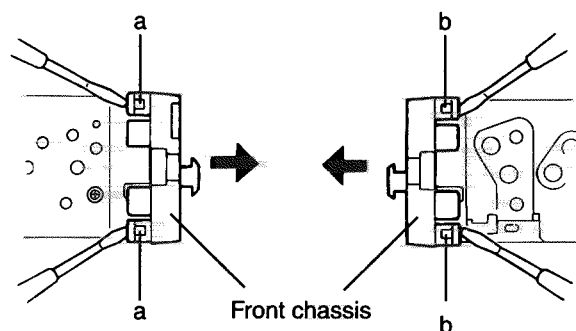

Fig.2

### ■ Removing the heat sink (See Fig.3)

1. Remove the three screws A attaching the heat sink on the left side of the body, and remove the heat sink.

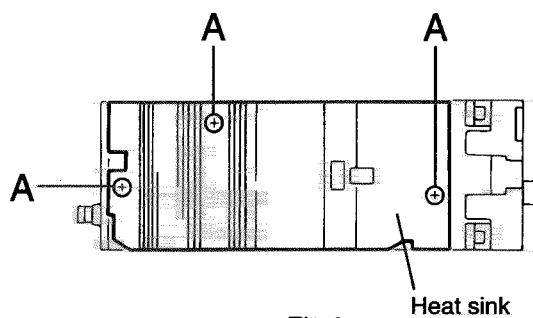

Fig.3

### ■ Removing the bottom cover (See Fig.4)

1. Turn the body upside down.
2. Insert a screwdriver to the two joints c and two joints d on both sides of the body and the joint e on the back of the body, then detach the bottom cover from the body.

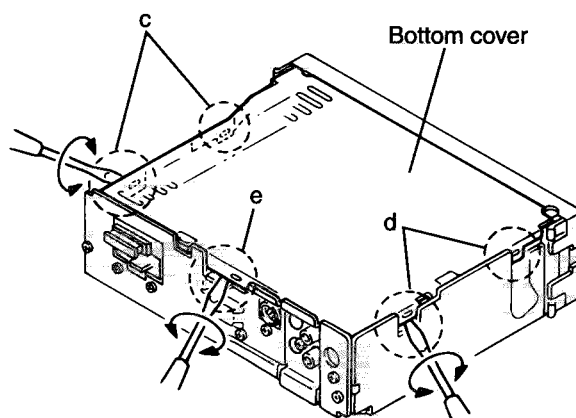

Fig.4

■ **Removing the main amplifier board assembly (See Fig.5 and 6)**

1. Remove the front panel assembly.
2. Remove the bottom cover.
3. Remove the two screws B attaching the main amplifier board assembly on the bottom of the body.
4. Remove the three screws C attaching the main amplifier board assembly on the back of the body.
5. Disconnect connector CN501 and CN502 on the main amplifier board assembly from the CD mechanism assembly.

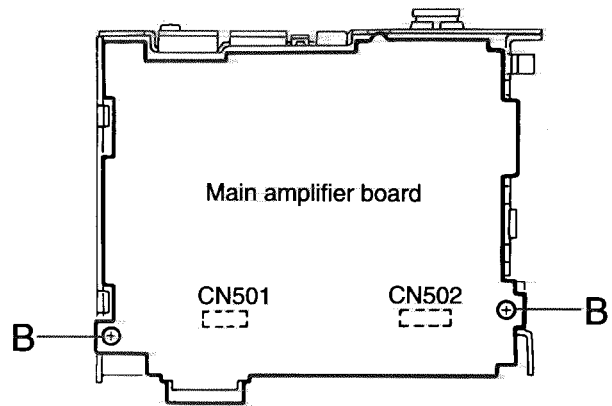

Fig.5

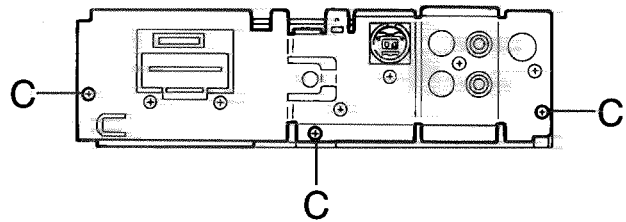

Fig.6

■ **Removing the CD mechanism assembly (See Fig.7)**

1. Remove the front panel assembly.
2. Remove the bottom cover.
3. Remove the main amplifier board assembly.
4. Remove the three screws D attaching the CD mechanism assembly from the top cover.

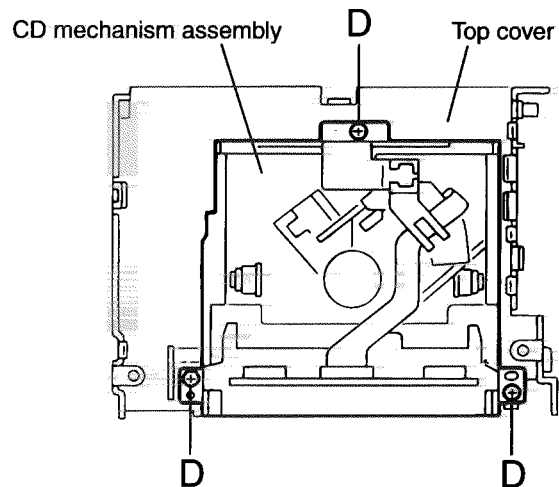

Fig.7

■ **Removing the control switch board (See Fig.8 and 9)**

1. Remove the front panel assembly.
2. Remove the four screws E attaching the rear cover on the back of the front panel unit.
3. Remove the control switch board from the front panel unit.

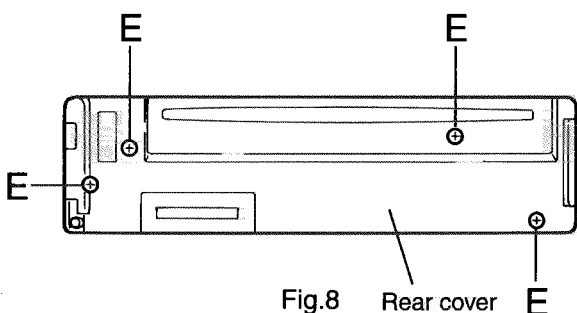

Fig.8

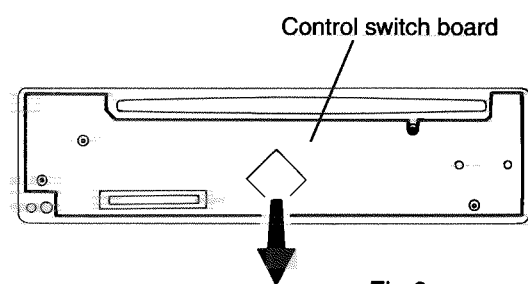

Fig.9

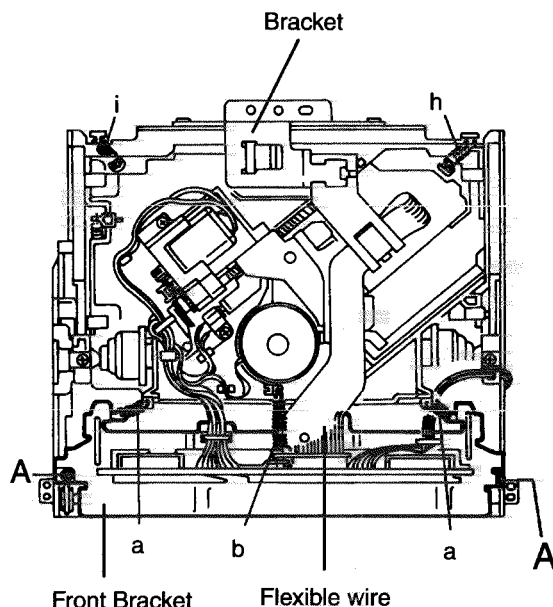

Fig.1

## [ CD mechanism section ]

### ■ Removing the CD mechanism control P.C.board

- 1.Remove the CD mechanism assembly  
(See "Removing the CD mechanism assembly").
- 2.Remove the three springs a and b from behind the CD mechanism assembly(See Fig.1).
- 3.Disc connect the flexible wire connected to the connector on the CD mechanism control P.C.board  
(See Fig.1).
- 4.Remove the one screw B retaining the CD mechanism control P.C.board(See Fig. 2).
5. After disengaging the engagement between the notch section c and frame,remove the CD mechanism Control P.C .board successively from 1 through to 3 in the arrow direction as shown in Fig. 2.

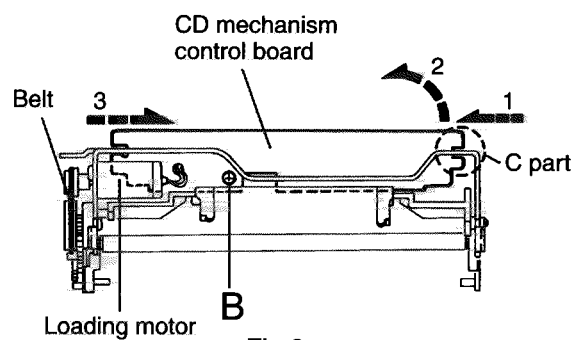

Fig.2

**CAUTION:**Whenever the flexible wire is disconnected, be sure to remove the soldering in advance as shown in Fig.3. Otherwise, the CD mechanism assembly can possibly be damaged.

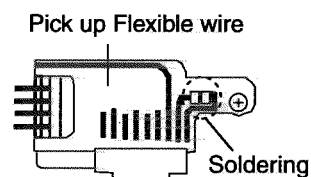

Fig.3

- 6.Remove the two screws A retaining the front bracket for fixing the CD mechanism control P. C. board(See Fig.1).

**CAUTION:**Remove the front bracket from the frame while expanding both sides of the frame as shown in Fig.5

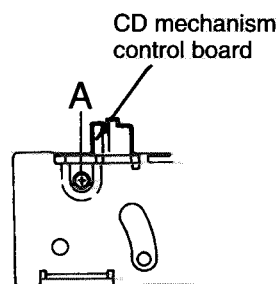

Fig.4

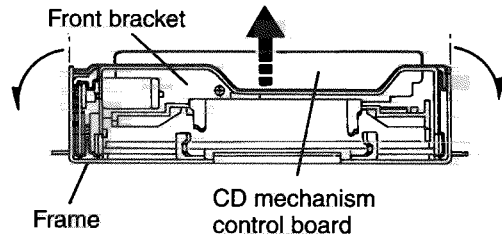

Fig.5

**■ Removing the loading motor**

- 1.Remove the belt from the loading motor (See Fig.14 and Fig.15)
- 2.Remove the one screw C retaining the loading motor(See Fig.15)

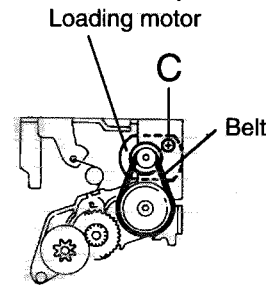

Fig.6

**■ Removing the CD mechanism assembly**

- 1.Remove the two screws D retaining the bracket for fixing the damper(See Fig.7)
- 2.While shifting the fix places on the right and left Sides respectively to the arrow direction, lower the entire CD mechanism. When the shafts(d , e , f and g ) on both the right and left sides have been set free as shown in Fig.8 and Fig.9,then the assembly can be removed easily.Remove the two screws E retaining the rear damper bracket to make it easier to remove the damper from the rear damper bracket(See Fig.1, Fig.8 and Fig.9).
- 3.Remove the two springs h and i as shown in Fig.1 and Fig.7.
- 4.While removing the right and left sides of the rear damper brackets and dampers. While expanding both sides of the CD mechanism,disassemble the entire CD mechanism.

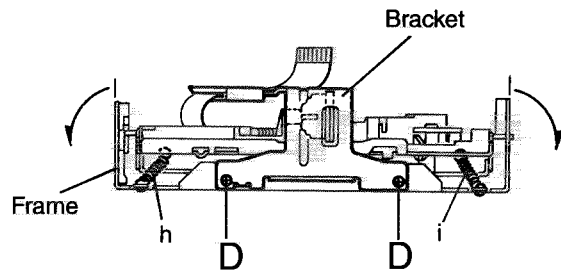

Fig.7

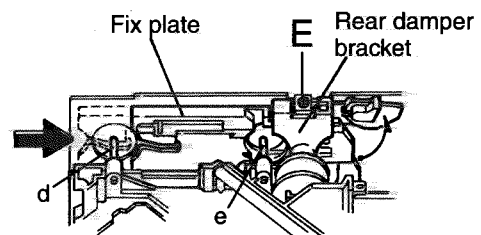

Fig.8

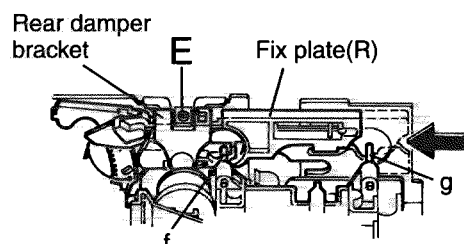

Fig.9

5. While tuning the pickup gear in the arrow direction as shown in Fig.11, shift the entire pickup unit.

6. Remove the three screws F retaining the feed motor assembly and take out this motor assembly (See Fig.10).

7. While pressing and expanding the spring section holding the FD screw in the arrow direction, remove the FD screw and dismount the pickup unit (See Fig.12).

8. By removing the two screw G retaining the pickup unit, dismount the nut push spring plate and pickup mount nut (See Fig.13).

9. Remove the FD screw from the pickup unit (See Fig.13).

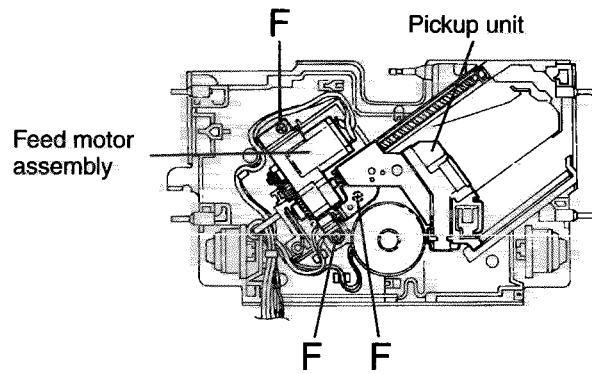

Fig.10

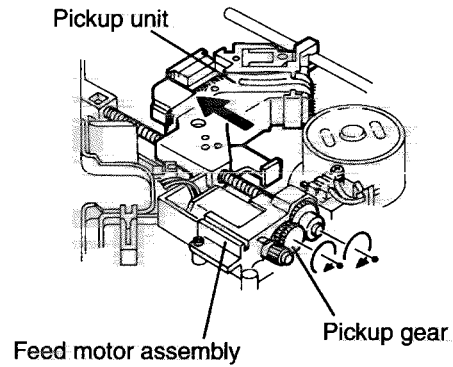

Fig.11

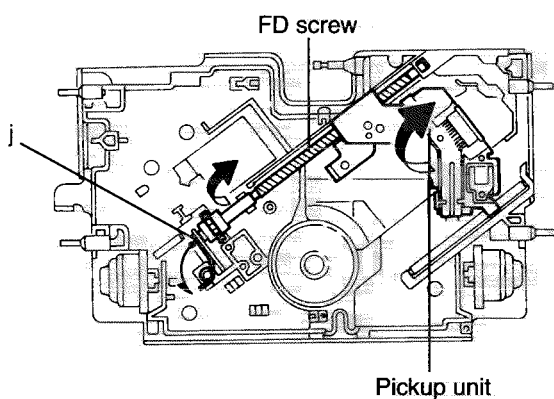

Fig.12

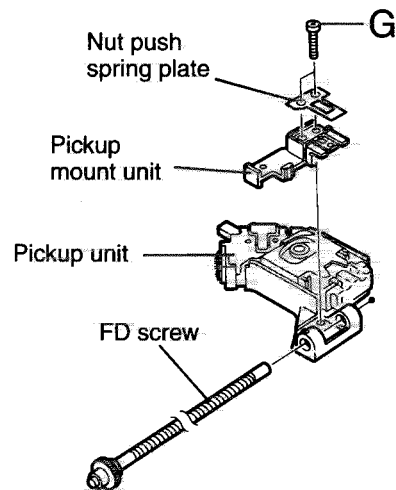

Fig.13

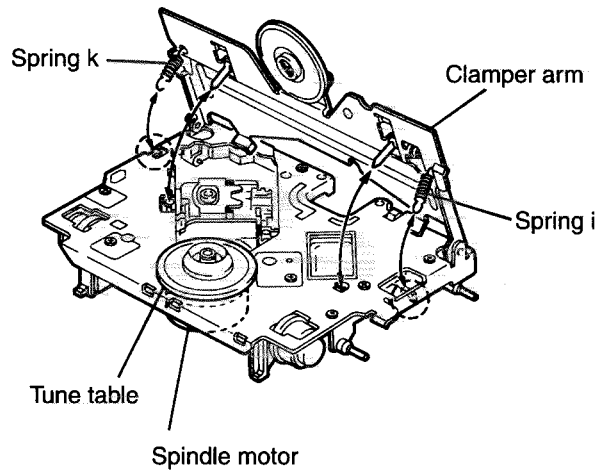

Fig. 14

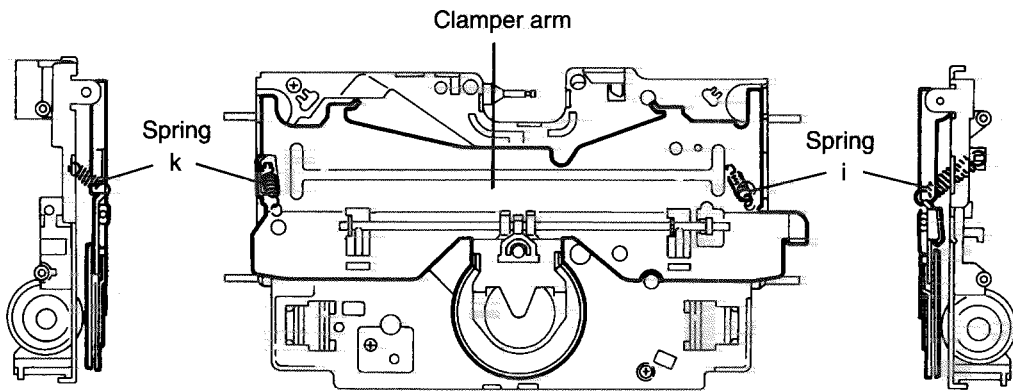

Fig. 15-a

Fig. 15

Fig. 15-b

### ■ Removing the spindle motor

1. After turning back the CD mechanism to initial position, remove the two sparrings k and i on both the right and left sides of the clamper arm (See Fig. 14 and Fig. 15).
2. While turning the turntable, remove the two screws H retaining the spindle motor and take out the spindle motor (See Fig. 16).

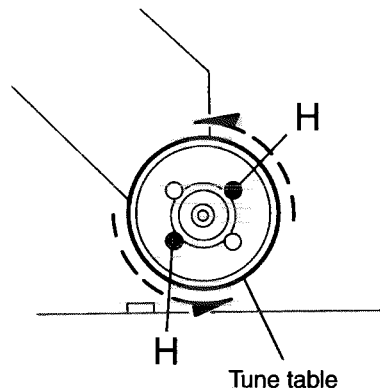

Fig. 16

## Adjustment method

### ■ Test instruments required for adjustment

1. Digital oscilloscope (100MHz)
2. AM Standard signal generator
3. FM Standard signal generator
4. Stereo modulator
5. Electric voltmeter
6. Digital tester
7. Tracking offset meter
8. Test Disc JVC :CTS-1000
9. Extension cable for check  
EXTGS003-14P×1  
EXTGS003-12P×2

### ■ Standard volume position

Balance and Bass & Treble volume : Indication "0"  
Loudness : OFF  
BBE : OFF  
Frequency Band

### ■ FM 87.5MHz ~ 108.0MHz

MW 522kHz ~ 1620 kHz

LW 144kHz ~ 279kHz

### ■ Dummy load

Exclusive dummy load should be used for AM, and FM. For FM dummy load, there is a loss of 6dB between SSG output and antenna input. The loss of 6dB need not be considered since direct reading of figures are applied in this working standard.

### ■ Standard measuring conditions

Power supply voltage DC14.4V(10.5~16V)

Load impedance 20Kohm(2 Speakers connection)

Output Level Line out 2.0V (Vol. MAX)

### ■ How to connect the extension cable for adjusting

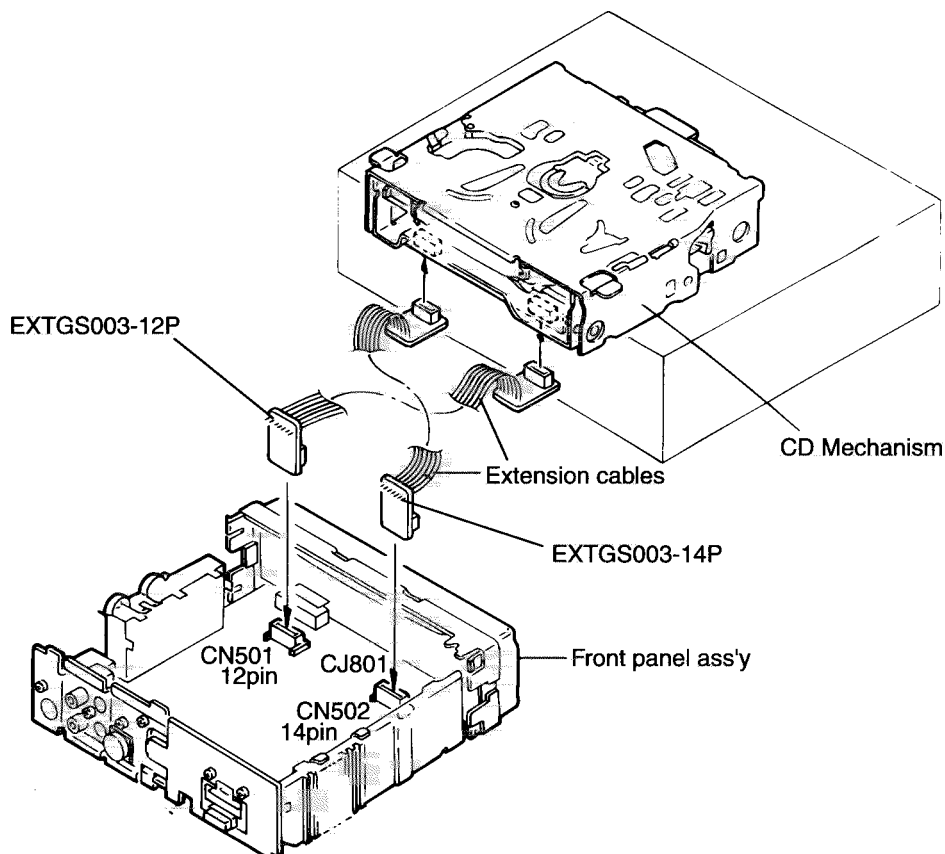

# Flow of functional operation until TOC read

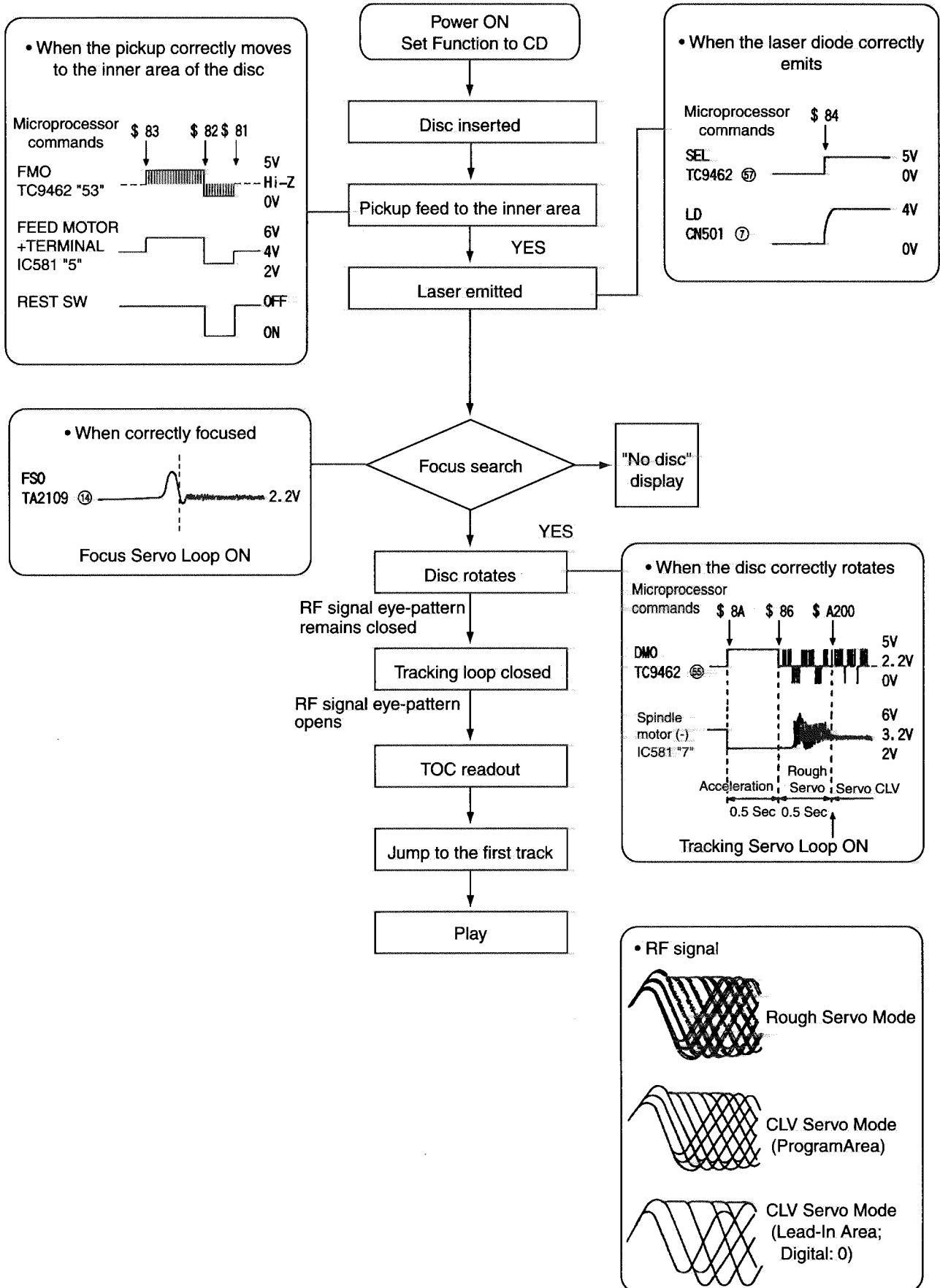



■ Feed Section

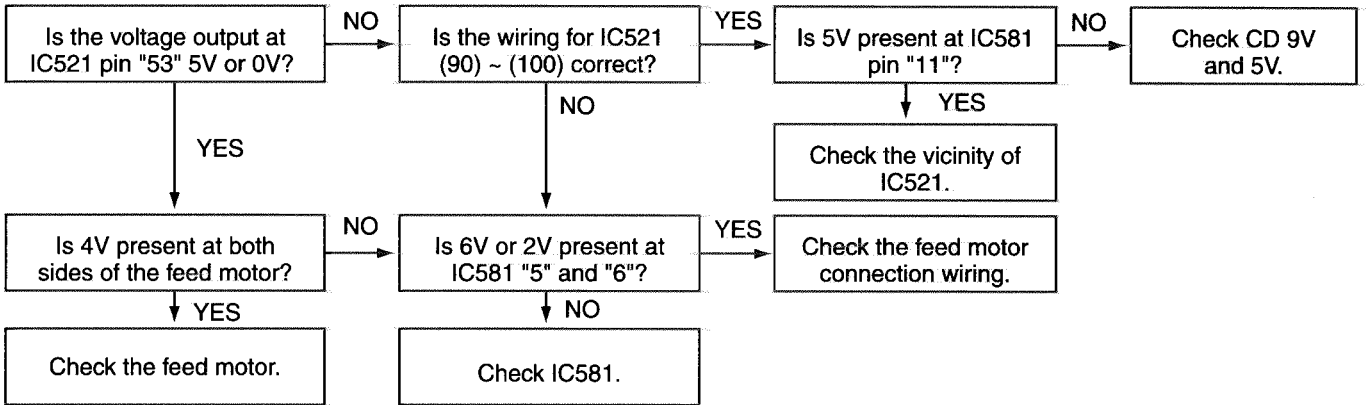

■ Focus Section

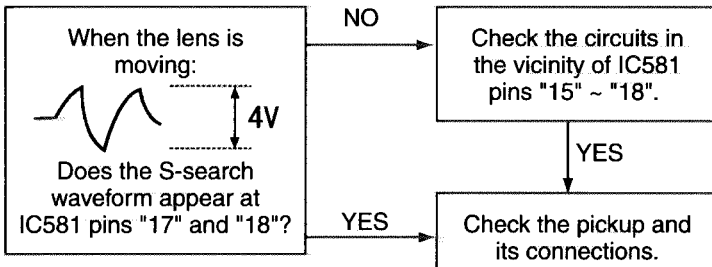

■ Spindle Section

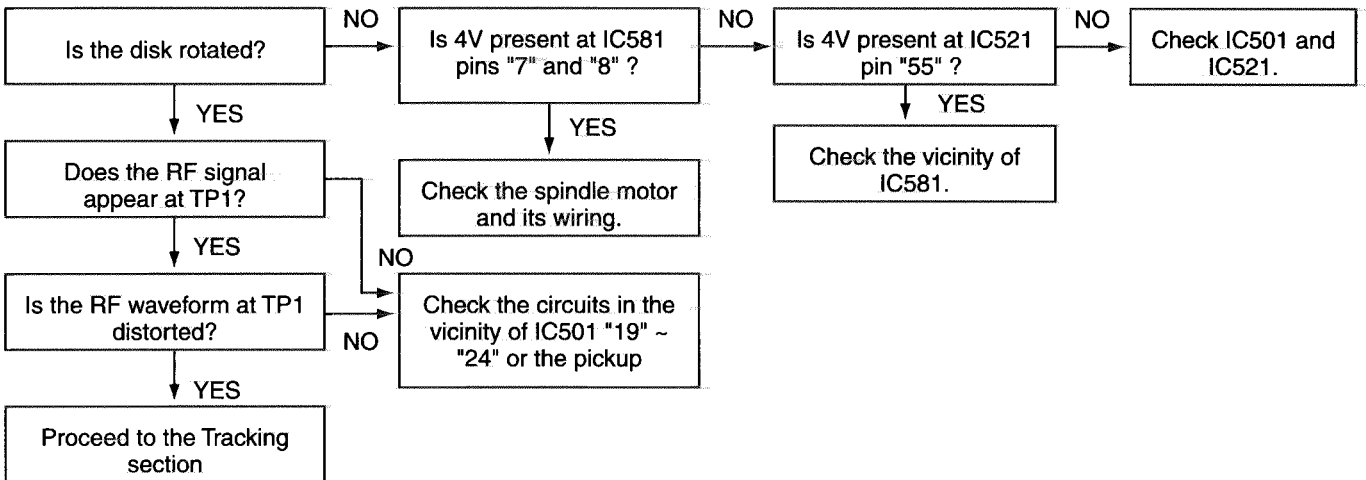

■ Tracking Section

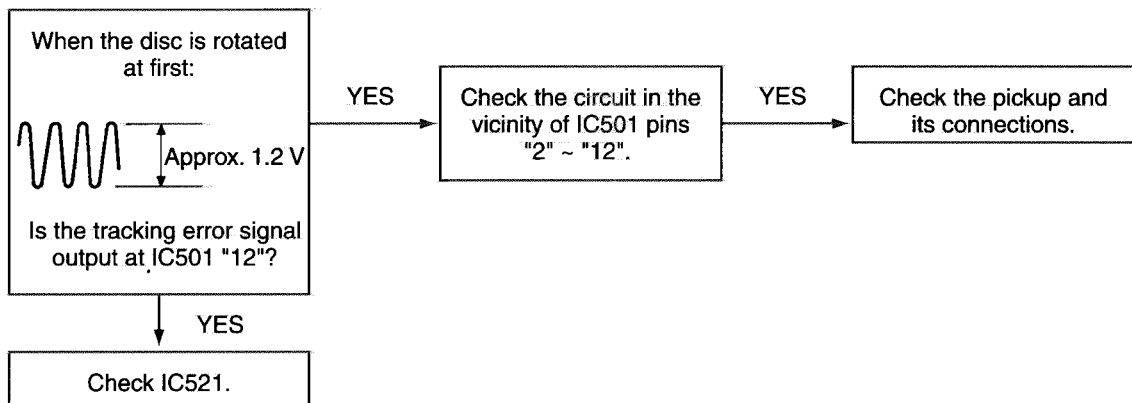

## Maintenance of laser pickup

- (1) Cleaning the pick up lens  
Before you replace the pick up, please try to clean the lens with a alcohol soaked cotton swab.
- (2) Life of the laser diode  
When the life of the laser diode has expired, the following symptoms will appear.
  - (1) The level of RF output (EFM output:amplitude of eye pattern) will be low.

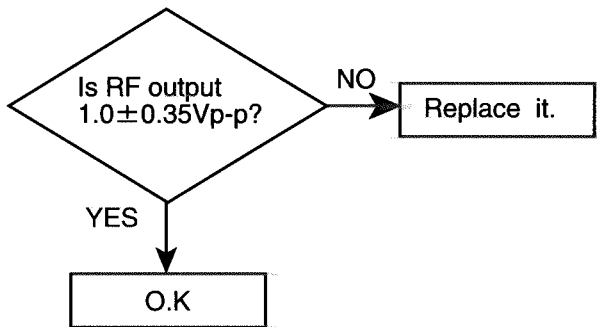

- (3) Semi-fixed resistor on the APC PC board  
The semi-fixed resistor on the APC printed circuit board which is attached to the pickup is used to adjust the laser power. Since this adjustment should be performed to match the characteristics of the whole optical block, do not touch the semi-fixed resistor.  
If the laser power is lower than the specified value, the laser diode is almost worn out, and the laser pickup should be replaced.  
If the semi-fixed resistor is adjusted while the pickup is functioning normally, the laser pickup may be damaged due to excessive current.

## Replacement of laser pickup

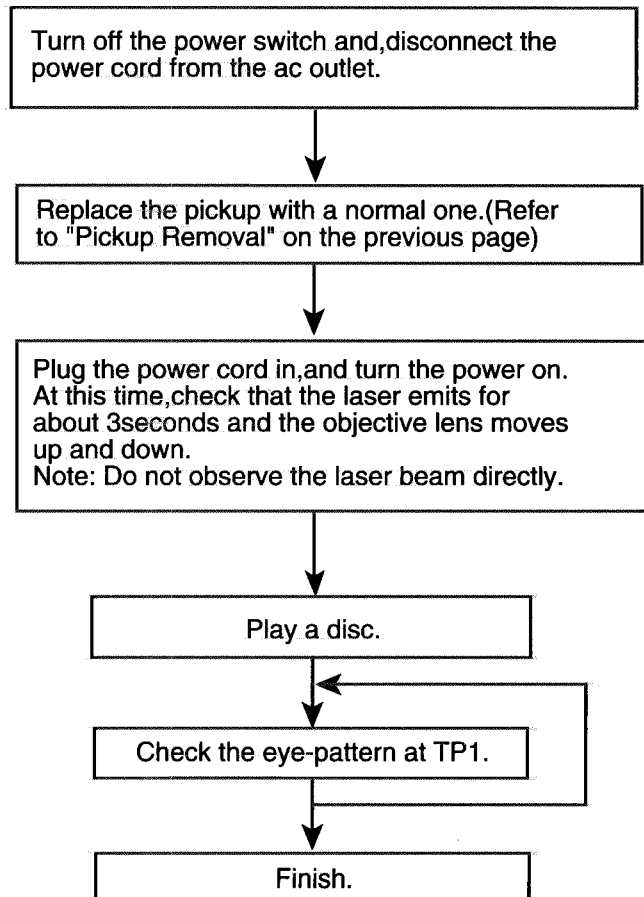

# Description of major ICs

## LA6541-X(IC541) : Servo Driver

### 1. Pin Layout & Block Diagram

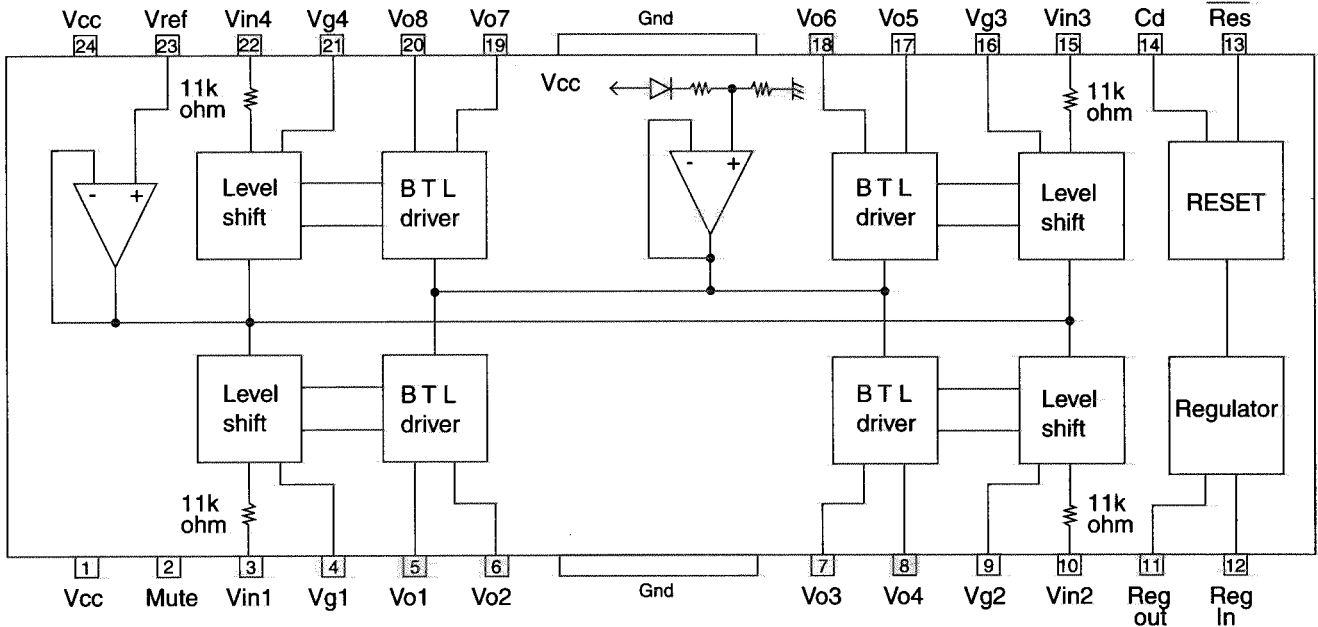

### 2. Pin functions

Pin No.	Symbol	Function
1	Vcc	Power supply (Shorted to pin 24)
2	Mute	All BTL amplifier outputs ON/OFF
3	Vin1	BTL AMP 1 input pin
4	Vg1	BTL AMP 1 input pin (For gain adjustment)
5	Vo1	BTL AMP 1 input pin (Non inverting side)
6	Vo2	BTL AMP 1 input pin (Inverting side)
7	Vo3	BTL AMP 2 input pin (Inverting side)
8	Vo4	BTL AMP 2 input pin (Non inverting side)
9	Vg2	BTL AMP 2 input pin (For gain adjustment)
10	Vin2	BTL AMP 2 input pin
11	Reg Out	External transistor collector (PNP) connection. 5V power supply output
12	Reg In	External transistor (PNP) base connection
13	Res	Reset output
14	Cd	Reset output delay time setting (Capacitor connected externally)
15	Vin3	BTL AMP 3 input pin
16	Vg3	BTL AMP 3 input pin (For gain adjustment)
17	Vo5	BTL AMP 3 output pin (Non inverting side)
18	Vo6	BTL AMP 3 output pin (Inverting side)
19	Vo7	BTL AMP 4 output pin (Inverting side)
20	Vo8	BTL AMP 4 output pin (Non inverting side)
21	Vg4	BTL AMP 4 output pin (For gain adjustment)
22	Vin4	BTL AMP 4 output pin
23	Vref	Level shift circuit's reference voltage application
24	Vcc	Power supply (Shorted to pin 1)

■ AN8806SB-W(IC601):RF&SERVO AMP

1.Pin layout

PD	1	36	PDAC
LD	2	35	PDBD
LDON	3	34	PDF
LDP	4	33	PDE
VCC	5	32	PDER
RF-	6	31	PDFR
RF OUT	7	30	TBAL
RF IN	8	29	FBAL
C. AGC	9	28	EF-
ARF	10	27	EF OUT
C. ENV	11	26	TE-
C. EA	12	25	TE OUT
CS BDO	13	24	CROSS
BDO	14	23	TE BPF
CS BRT	15	22	VDET
OFTR	16	21	LD OFF
/NRFDET	17	20	VREF
GND	18	19	ENV

2.Block diagram

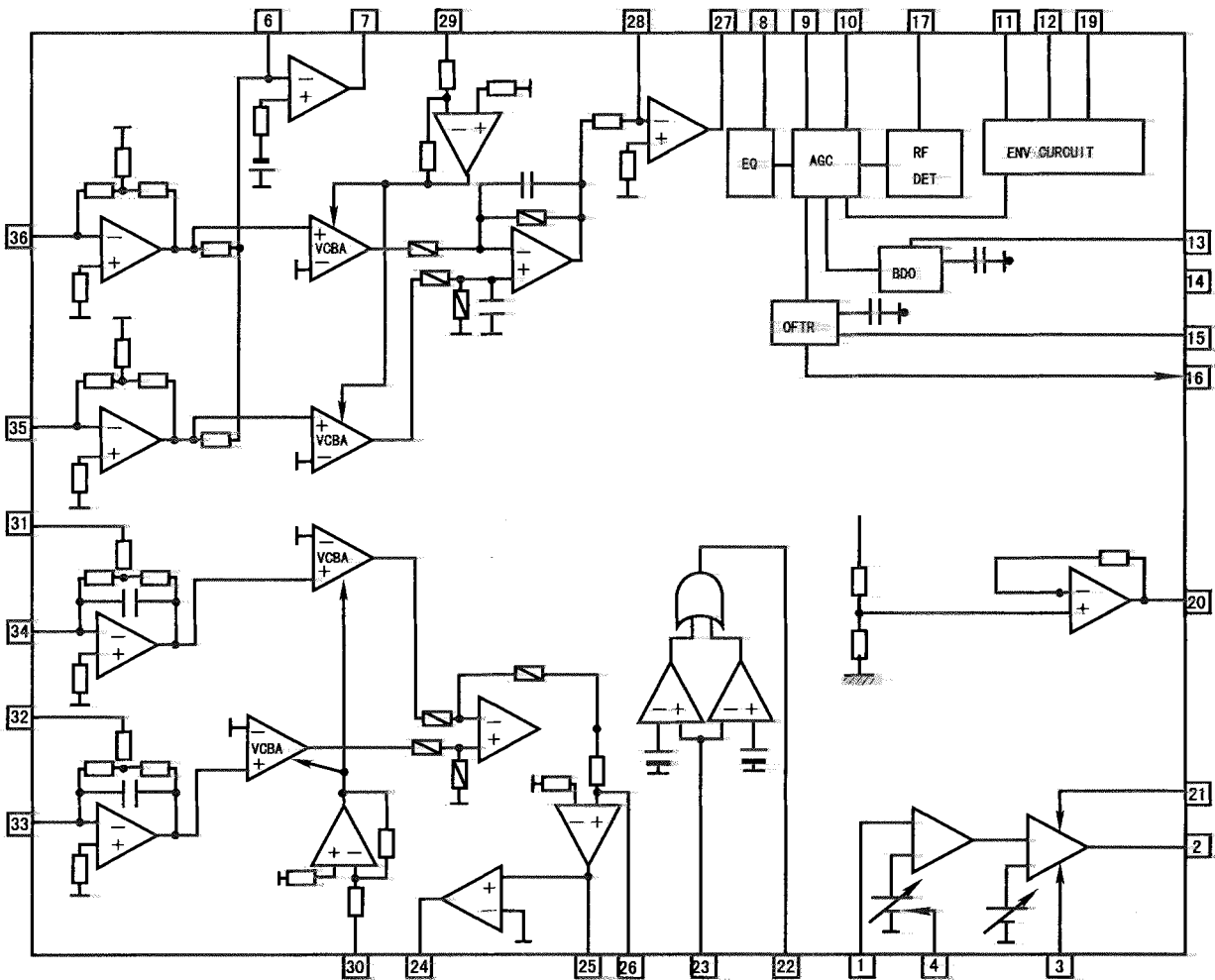

## 3. Pin function

Pin No.	symbol	I/O	Function
1	PD	I	APC amp . Input terminal
2	LD	O	APC amp . Output terminal
3	LD ON	I	LD ON/OFF control terminal
4	LDP	--	Connect to GND
5	VCC	--	Power supply
6	RF-	I	RF amp . Reversing input terminal
7	RF OUT	O	RFamp . Output terminal
8	RF IN	I	AGC input terminal
9	C.AGC	I/O	AGC loop filter connection terminal
10	ARF	O	ARF output terminal
11	C.ENV	I/O	RF detection capacity connection terminal
12	C.EA	I/O	HPF-amp capacity connection terminal
13	CS BDO	I/O	Capacity connection terminal for RF discernment side envelope detection
14	BDO	O	BDO output terminal
15	CS BRT	I/O	Capacity connection terminal for RF discernment side envelope detection
16	OFTR	O	OFTR output terminal
17	/NRFDET	O	RFDET output terminal
18	GND	--	Connect to GND
19	ENV	O	3TENV output terminal
20	VREF	O	VREF output terminal
21	LD OFF	--	APC OFF control terminal
22	VDET	O	VDET output terminal
23	TE BPF	I	VDET input terminal
24	CROSS	O	CROSS output terminal
25	TE OUT	O	TE amp . Output terminal
26	TE-	I	FE amp . Reversing input terminal
27	FE OUT	O	FE amp . output terminal
28	FE-	I	FE amp . Reversing input terminal
29	FBAL	I	F.BAL control terminal
30	TBAL	I	T.BAL control terminal
31	PDFR	I/O	I-V amp conversion resistance adjustment terminal
32	PDER	I/O	I-V amp conversion resistance adjustment terminal
33	PDF	I	I-V amp input terminal
34	PDE	I	I-V amp input terminal
35	PD BD	I	I-V amp input terminal
36	PD AC	I	I-V amp input terminal

**MN35510(IC651):DIGITAL SERVO&DIGITAL SIGNAL PROCESSER**

1. Terminal Layout

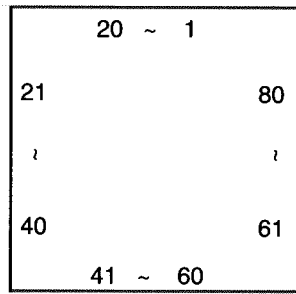

2. Block Diagram

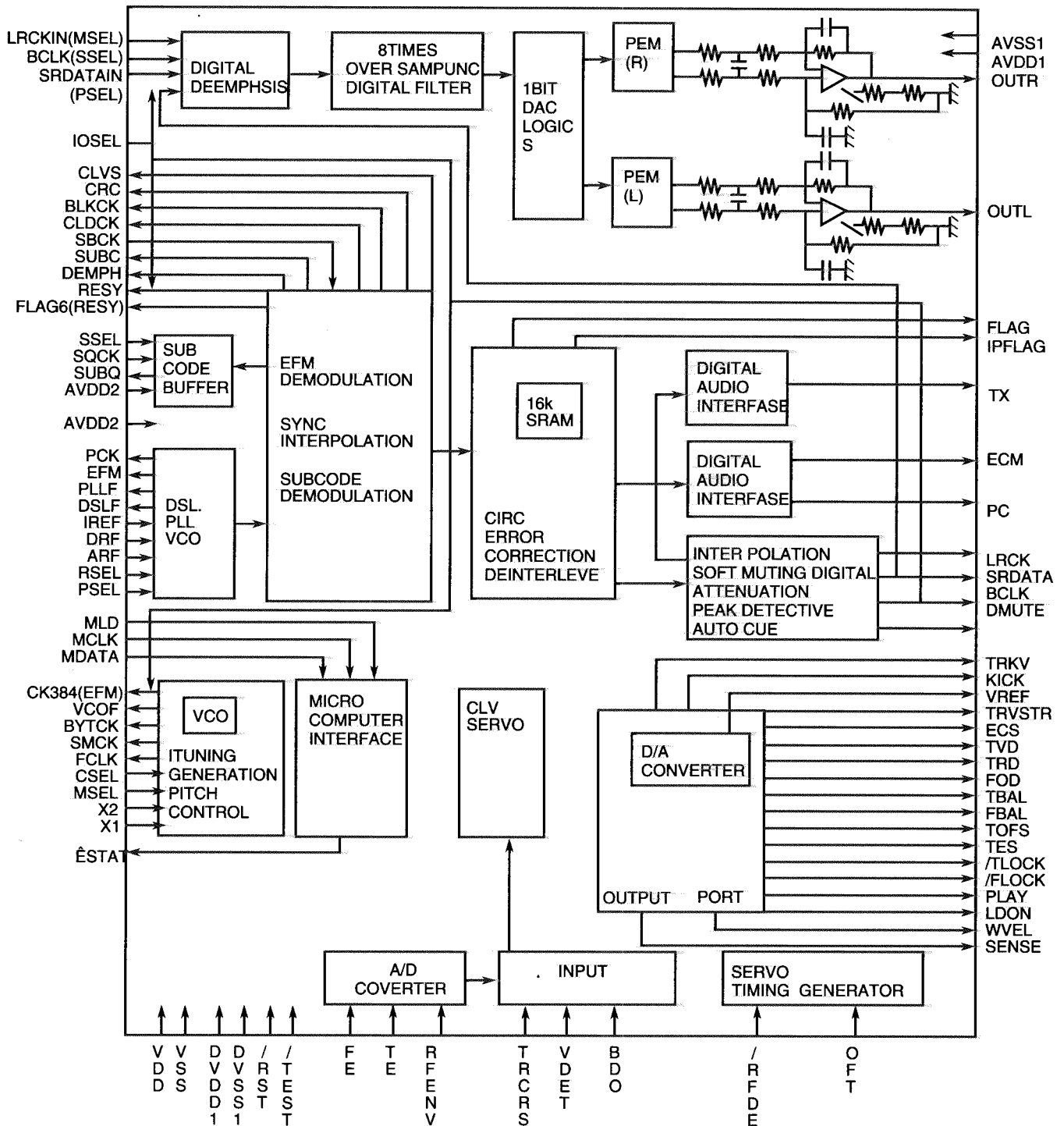

## 3. Description

Pin No.	symbol	I/O	Description	Pin No.	symbol	I/O	Description
1	BCLK	O	Not used	41	TES	O	Tracking error shunt signal output(H:shunt)
2	LRCK	O	Not used	42	PLAY	-	Not used
3	SRDATA	O	Not used	43	WVEL	-	Not used
4	DVDD1	-	Power supply (Digital)	44	ARF	I	RF signal input
5	DVSS1	-	Connected to GND	45	IREF	I	Reference current input pin
6	TX	O	Digital audio interface output	46	DRF	I	Bias pin for DSL
7	MCLK	I	Micom command clock signal input (Data is latched at signal's rising point)	47	DSLFL	I/O	Loop filter pin for DSL
8	MDATA	I	Micom command data input	48	PLLF	I/O	Loop filter pin for PLL
9	MLD	I	Micom command load signal input	49	VCOF	-	Not used
10	SENSE	O	Sence signal output	50	AVDD2	-	Power supply(Analog)
11	FLOCK	O	Focus lock signal output Active :Low	51	AVSS2	-	Connected to GND(Analog)
12	TLOCK	O	Tracking lock signal output Active :Low	52	EFM	-	Not used
13	BLKCK	O	sub-code - block - clock signal output	53	PCK	-	Not used
14	SQCK	I	Outside clock for sub-code Q register input	54	PDO	-	Not used
15	SUBQ	O	Sub-code Q -code output	55	SUBC	-	Not used
16	DMUTE	-	Connected to GND	56	SBCK	-	Not used
17	STATUS	O	Status signal (CRC,CUE,CLVS,TTSTOP,ECLV,SQOK)	57	VSS	-	Connected to GND(for X'tal oscillation circuit)
18	RST	I	Reset signal input (L:Reset)	58	X1	I	Input of 16.9344MHz X'tal oscillation circuit
19	SMCK	-	Not used	59	X2	O	Output of X'tal oscillation circuit
20	PMCK	-	Not used	60	VDD	-	Power supply(for X'tal cscillation circuit)
21	TRV	O	Traverse enforced output	61	BYTCK	-	Not used
22	TVD	O	Traverse drive output	62	CLDCK	-	Not used
23	PC	-	Not used	63	FLAG	-	Not used
24	ECM	O	Spindle motor drive signal (Enforced mode output) 3-State	64	IPPLAG	-	Not used
25	ECS	O	Spindle motor drive signal (Servo error signal output)	65	FLAG	-	Not used
26	KICK	O	Kick pulse output	66	CLVS	-	Not used
27	TRD	O	Tracking drive output	67	CRC	-	Not used
28	FOD	O	Focus drive output	68	DEMPH	-	Not used
29	VREF	I	Reference voltage input pin for D/A output block (TVD,FOD,FBA,TBAL)	69	RESY	-	Not used
30	FBAL	O	Focus Balance adjust signal output	70	IOSEL	-	pull up
31	TBAL	O	Tracking Balance adjust signal output	71	TEST	-	pull up
32	FE	I	Focus error signal input(Analog input)	72	AVDD1	-	Power supply(Digital)
33	TE	I	Tracking error signal input(Analog input)	73	OUT L	O	Lch audio output
34	RF ENV	I	RF envelope signal input(Analog input)	74	AVSS1	-	Connected to GND
35	VDET	I	Vibration detect signal input(H:detect)	75	OUT R	O	Rch audio output
36	OFT	I	Off track signal input(H:off track)	76	RSEL	-	pull up
37	TRCRS	I	Track cross signal input	77	CSEL	-	Connected to GND
38	RFDET	I	RF detect signal input(L:detect)	78	PSEL	-	Connected to GND
39	BDO	I	BDO input pin(L:detect)	79	MSEL	-	Connected to GND
40	LDON	O	Laser ON signal output(H:on)	80	SSEL	-	Pull up

■ BA4901A-V3 (IC961) : Regulator

1. Pin layout

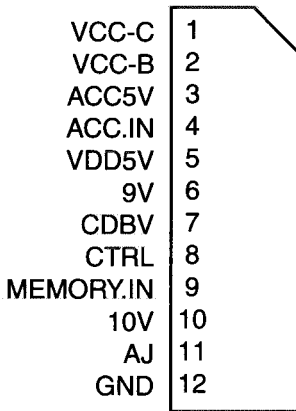

2.Pin Function

Pin No.	Symbol	Descriptions
1	VCC-C	To be connected with the collector of PNP.
2	VCC-B	To be connected with the base of PNP.
3	ACC5V	A voltage supply for ACC block.
4	ACC.IN	Control of the COMP output by inputting voltage.
5	VDD5V	Output voltage level is 5.7V, and max output current is 100mA. This voltage supply is for microcomputer. Whenever backup voltage supply is connected, the output keeps on running.
6	9V	This output voltage is 9.0V, and max output current is 500mA. This voltage supply for AUDIO.
7	CDBV	This output voltage is 8.0V, and max output current is 1A This voltage supply for CD.
8	CTRL	Output selector of CD, AUDIO, ILM and Vcc-B.
9	MEMORY.IN	To be connected with the BACKUP of car
10	10V	This output voltage is 10V, and max output current is 500mA. Output voltage is adjustable.
11	AJ	Putting a resistance between ILM and AJ or between AJ and GND males ILM output voltage adjustable.
12	GND	Connect to GND

■ RPM6938-SV4 (IC852) : Remote control receiver

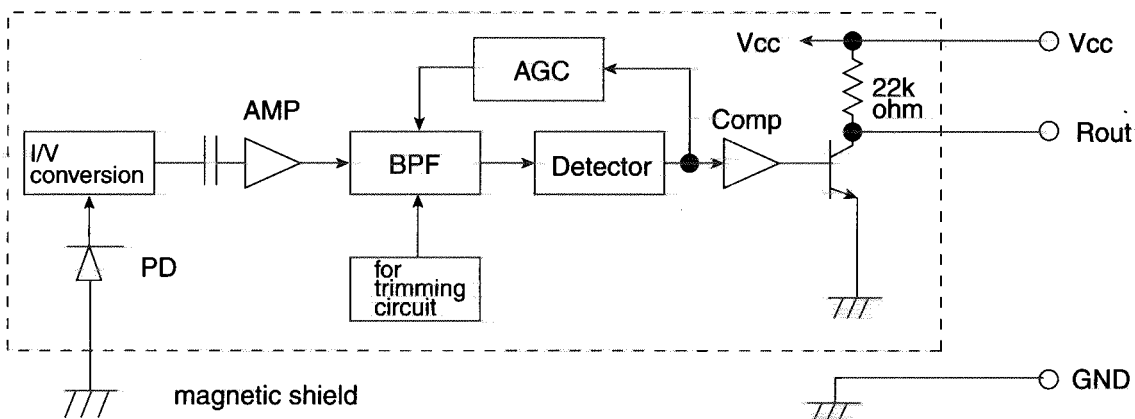



■ BA6218 (IC591) : Motor driver

1. Block diagram

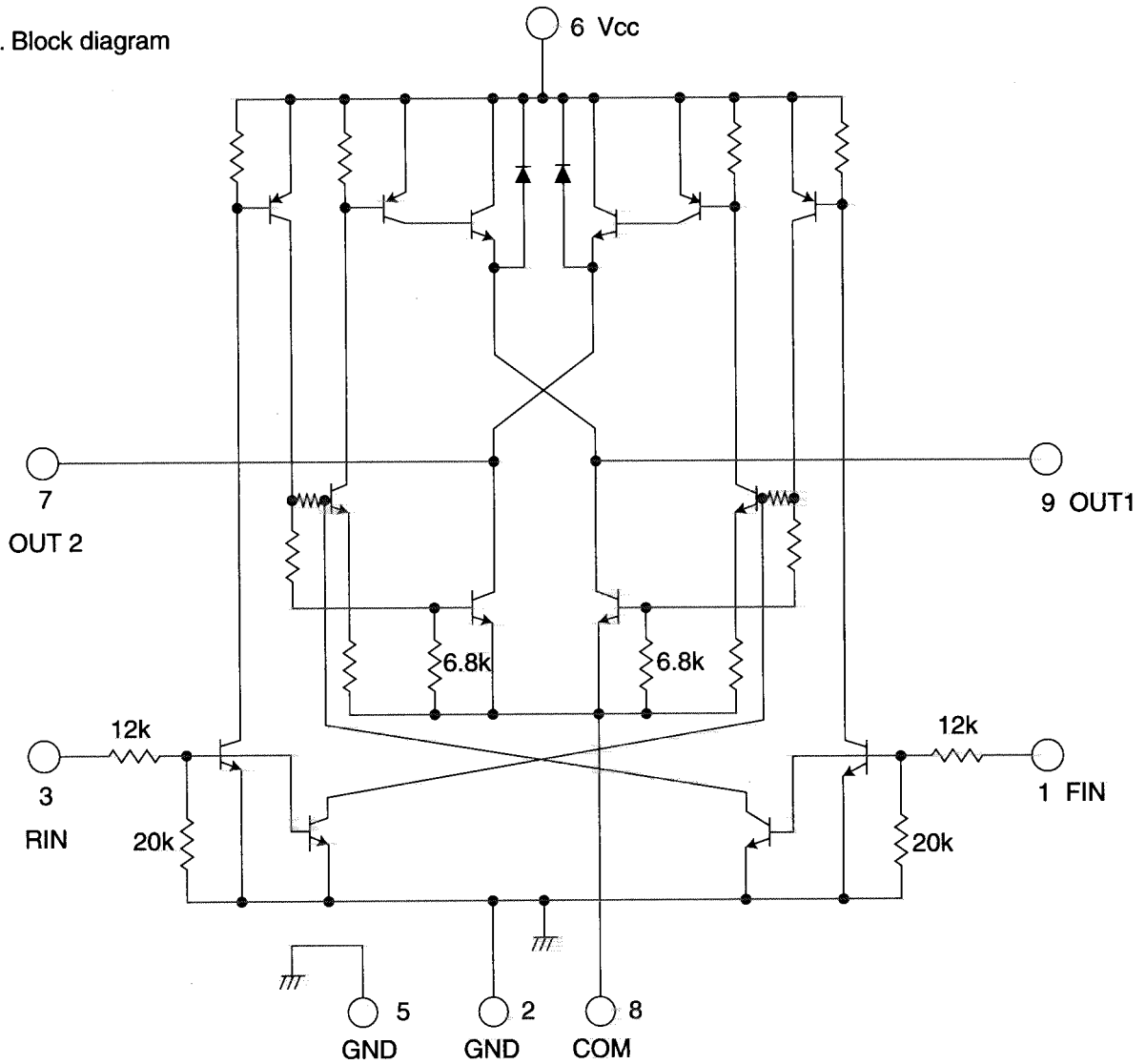

2. Function truth table

3Pin (IN)	1Pin (IN)	7Pin (OUT)	9Pin (OUT)
H	L	H	H
L	H	H	L
H	H	L	L
L	L	OPEN	OPEN

■ HA13158A (IC321) : Power amp

1. Pin layout

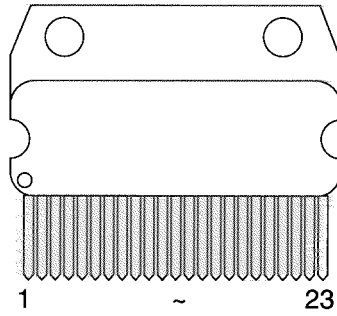

2. Block diagram

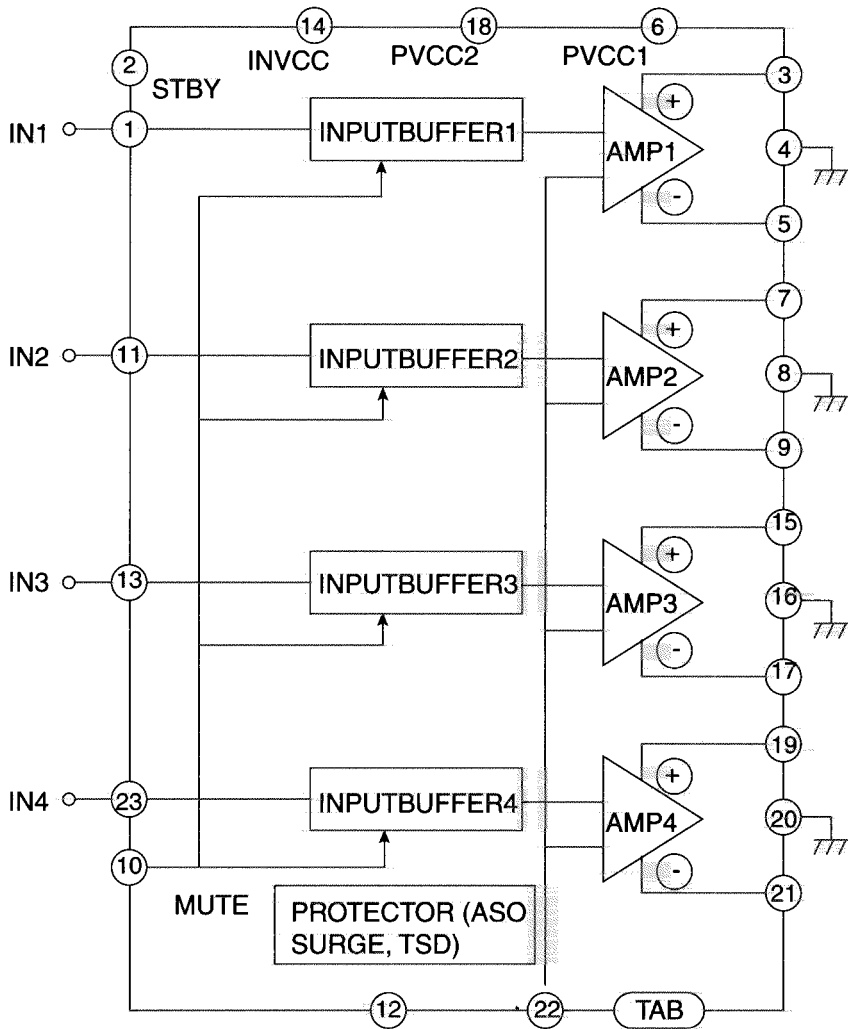

■ HD74HC126FP-X (IC771) : Buffer

1. Pin layout

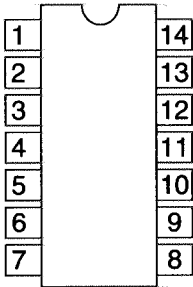

2. Function

Inputs		Outputs
C	A	Y
L	X	Z
H	L	H
H	H	L

3. Block diagram

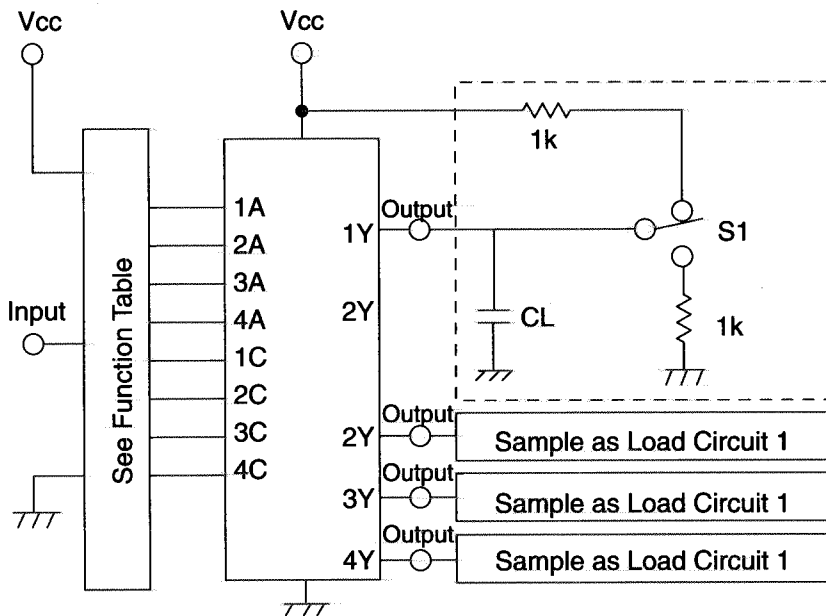

■ M5228FP-W (IC351) : Pre amp.

1. Pin layout & Block diagram

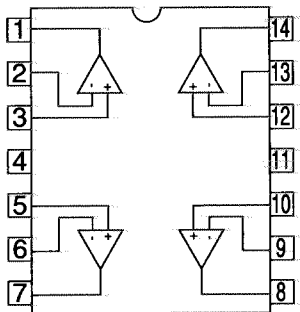

2. Pin function

Pin No.	Function	Pin No.	Function
1	Output1	8	Output3
2	Input1(-)	9	Input3(-)
3	Input1(+)	10	Input3(+)
4	Power supply	11	Ground
5	Input2(+)	12	Input4(+)
6	Input2(-)	13	Input4(-)
7	Output2	14	Output4

■ LC72363-9596 (IC601) : Main micon

1. Pin layout

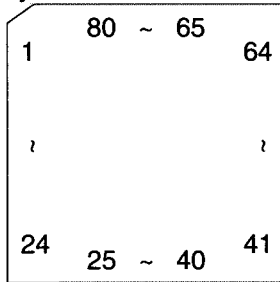

2. Pin function

Pin No.	Symbol	Function	Pin No.	Symbol	Function
1	XIN	4.5MHz crystal oscillation	41	CD ON	CD 8V supply on
2	TEST2	Connect to ground	42	RELAY	5V power control
3	J BUS SI	J-BUS signal data input ( to 74HC126 )	43	BBE CTL	No use
4	J BUS SO	J-BUS signal data output ( to 74HC126 )	44	BEEP	No use
5	J BUS SCK	J-BUS output clock signal ( to 74HC126 )	45		No use
6	J BUS I/O CONT	J-BUS I/O control	46	SW1	CD mechanism switch 1 for disc in, 8cm disc
7	SUBQ	CD LSI subcode data input	47	SW3	CD mecha. switch 3 for disc present, loading end
8		No use	48	REST	CD pickup rest position
9	SQCK	CD LSI subcode clock	49	JOG0	Rotary encoder input 0
10	RESET	Micon reset pin	50	JOG1	Rotary encoder input 1
11	LCD SI	No use	51	CD SENSE	CD LSI sense signal
12	LCD SO	LCD driver data output	52	STATUS	CD LSI status signal
13	LCDSCK	LCD driver clock signal	53	PSAVE2	Power save 2 : +B detect
14	LCD CE	LCD driver chip enable port	54	SD/ST	Station detection, Stereo indication
15	CD ILLUMI	Connect to LED	55	REMOCON	Remocon input
16	CD ILLUMI	Connect to LED	56	J BUS INT	J-BUS interrupt
17		No use	57	BAND	FM/AM band selection
18	DIMMER OUT	No use	58	MONO	FM mono selection
19	LM0	CD loading motor output	59	IFRQ/AGC	During FM auto search, IF request output H after SD
20	LM1	CD loading motor output			detected. During AM auto search, AGC output.
21		No use	60	MUTE	Muting switch
22		No use	61	LEVEL	Level meter input
23		No use	62	S METER	S meter input
24	KS2	Output for initial setting diode matrix	63	KEY CHANGE	Connect to ground
25	KS1	Output for initial setting diode matrix	64	KEY2	Key 2 data input (AD)
26	KS0	Output for initial setting diode matrix	65	KEY1	Key 1 data input (AD)
27	DETACH	Front panel detect	66	KEY0	Key 0 data input (AD)
28	K2	Input for initial setting diode matrix	67	PSAVE1	Power save 1, ACC power detect
29	K1	Input for initial setting diode matrix	68	SENSE	Voltage sense
30	K0	Input for initial setting diode matrix	69		No use
31	Vdd	5V power supply	70	FM IF COUNT	FM IF counter data input
32	SW2	CD mechanism switch 2 for 12cm disc	71		No use
33	CD LSI RESET	CD LSI reset	72		No use
34	MCLK	CD LSI command clock signal	73	Vdd	5V power supply
35	MDATA	CD LSI command data output	76	AM OSC	No use
36	MLD	CD LSI command load signal	75	FM OSC	FM input frequency
37		No use	76	Vss	Ground
38		No use	77		No use
39	SCL	E.volume clock output	78	EO	PLL error output signal
40	SDA	E.volume data output	79	TEST1	Connect to ground
			80	XOUT	4.5MHz crystal oscillation

■ LC75823E(IC851):LCD DRIVER

1. Terminal Layout

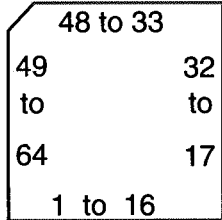

2. Block Diagram

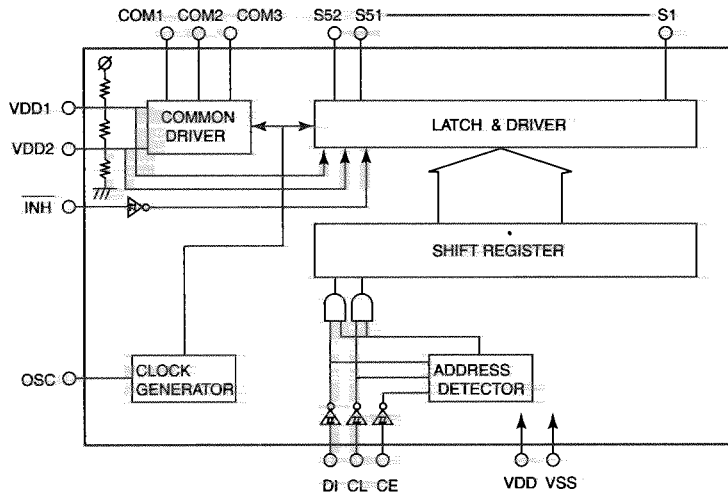

3. Pin Function

PIN No.	Symbol	I/O	Functions
1 to 9		-	NOT USED
10 to 52	S10 to S52	O	Segment outputs that display data transferred from serial data.
53 to 55	COM1 to COM3	O	The frame frequency (fo) for the common driver output is (fosc/384)Hz.
56	VDD	-	Power supply
57	/INH	I	Forcibly turns off the display, regardless of internal data. Serial data can be input, whether this pin is high or low
58		-	NOT USED
59		-	
60	VSS	-	To GND
61	OSC	I	Oscillator connection (for the common segment alternating waveform)
62	CE	I	Serial data transfer pins connected to a microprocessor.
63	CL	I	
64	DI	I	

CE : Chip enable  
 CL : Sync.clock  
 DI : Transfer data

TEA6320T-X (IC321) : E.VOLUME

1.Pin Layout

SDA	1	32	SCL
GND	2	31	VCC
OUTLR	3	30	OUTRR
OUTLF	4	29	OUTRF
TL	5	28	TR
B2L	6	27	B2R
B1L	7	26	B1R
IVL	8	25	IVR
ILL	9	24	ILR
QSL	10	23	QSR
IDL	11	22	IDR
MUTE	12	21	Vref
ICL	13	20	ICR
IMD	14	19	CAP
IBL	15	18	IBR
IAL	16	17	IAR
			CD-CH
			TAPE
			TUNER

2.Block Diagram

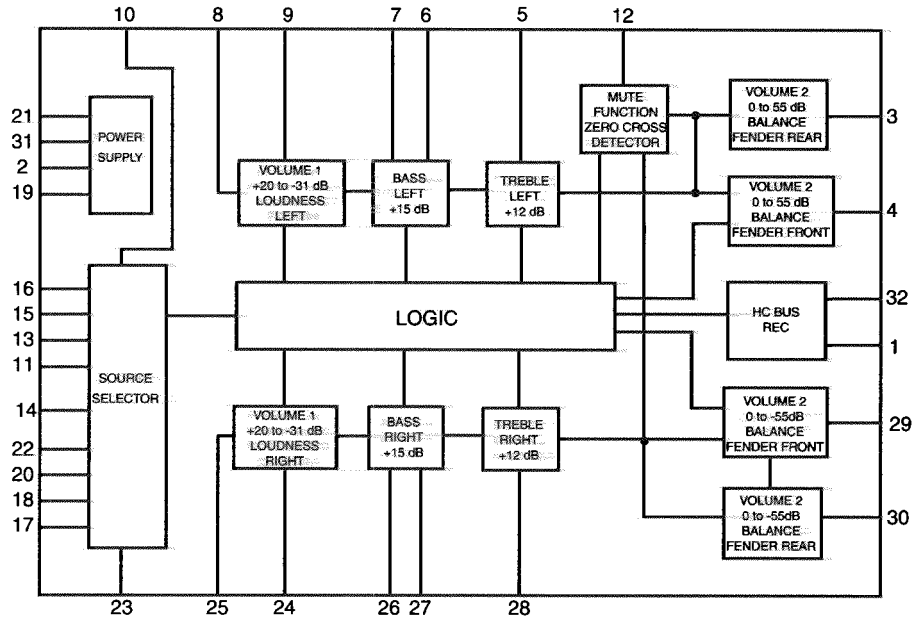

3.Pin Functions

Pin No.	Symbol	I/O	Functions	Pin No.	Symbol	I/O	Functions
1	SDA	I/O	Serial data input/output.	17	IAR	I	Input A right source.
2	GND	-	Ground.	18	IBR	I	Input B right source.
3	OUTLR	O	output left rear.	19	CAP	-	Electronic filtering for supply.
4	OUTLF	O	output left front.	20	ICR	I	Input C right source.
5	TL	I	Treble control capacitor left channel or input from an external equalizer.	21	Vref	-	Reference voltage (0.5Vcc)
6	B2L	-	Bass control capacitor left channel or output to an external equalizer.	22	IDR	-	Not used
7	B1L	-	Bass control capacitor left channel.	23	QSR	O	Output source selector right channel.
8	IVL	I	Input volume 1. left control part.	24	ILR	I	Input loudness right channel.
9	ILL	I	Input loudness. left control part.	25	IVR	I	Input volume 1. right control part.
10	QSL	O	Output source selector. left channel.	26	B1R	-	Bass control capacitor right channel
11	IDL	-	Not used	27	B2R	O	Bass control capacitor right channel or output to an external equalizer.
12	MUTE	-	Not used	28	TR	I	Treble control capacitor right channel or input from an external equalizer.
13	ICL	I	Input C left source.	29	OUTRF	O	Output right front.
14	IMO	-	Not used	30	OUTRR	O	Output right rear.
15	IBL	I	Input B left source.	31	Vcc	-	Supply voltage.
16	IAL	I	Input A left source.	32	SCL	I	Serial clock input.

# Block diagram

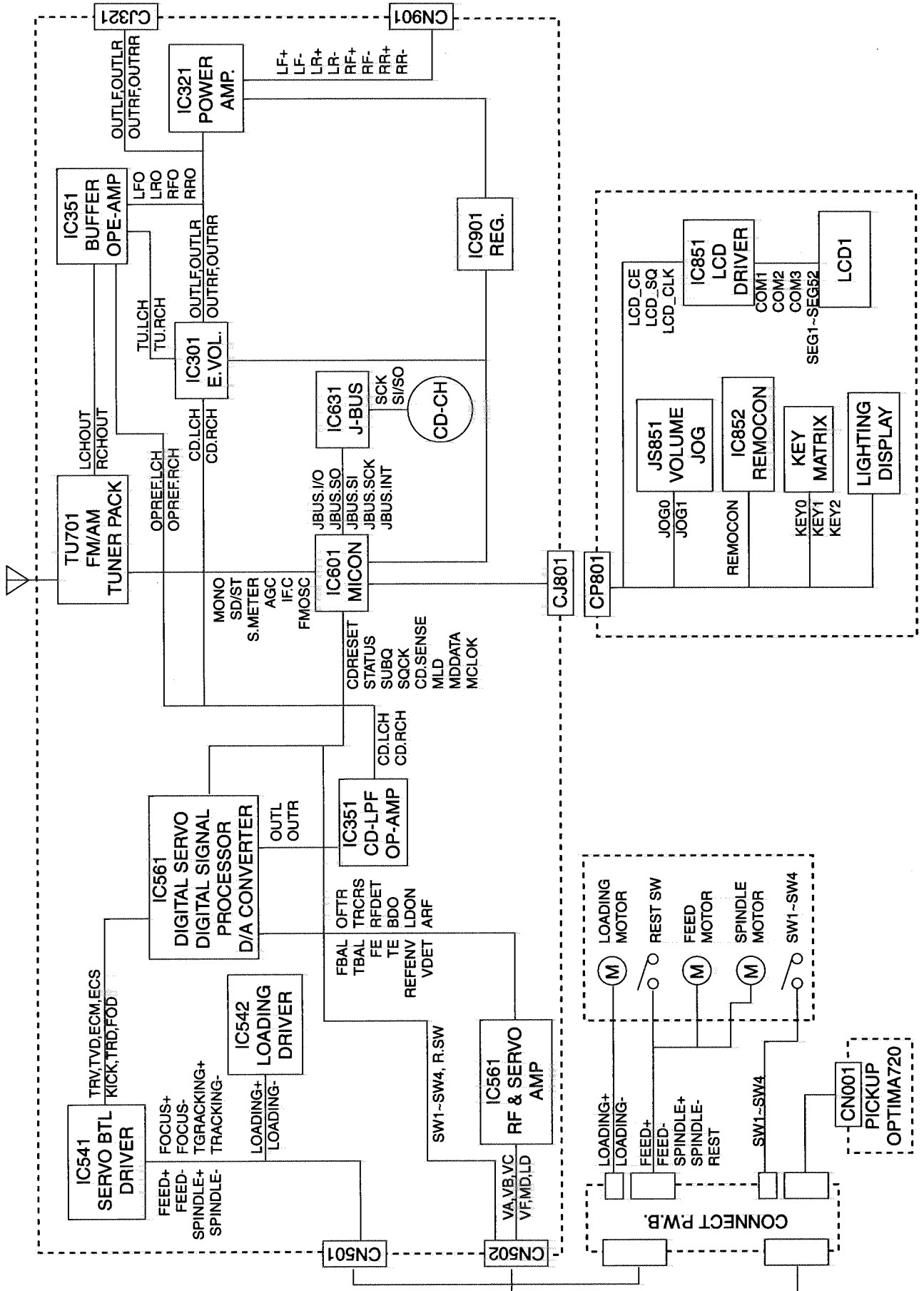

KD-SX650

<<MEMO>>





# Standard schematic diagrams

## ■ Main amp section

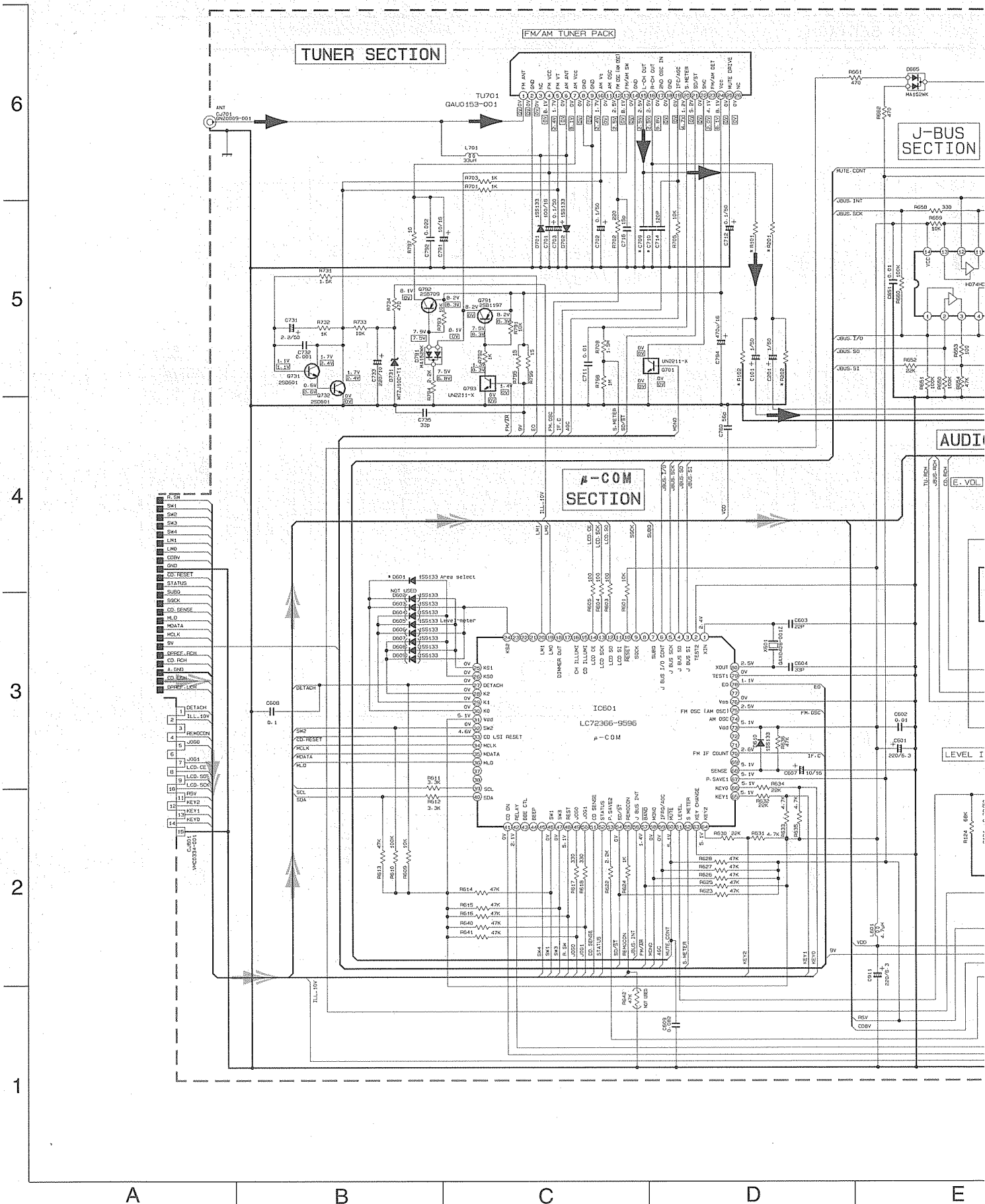

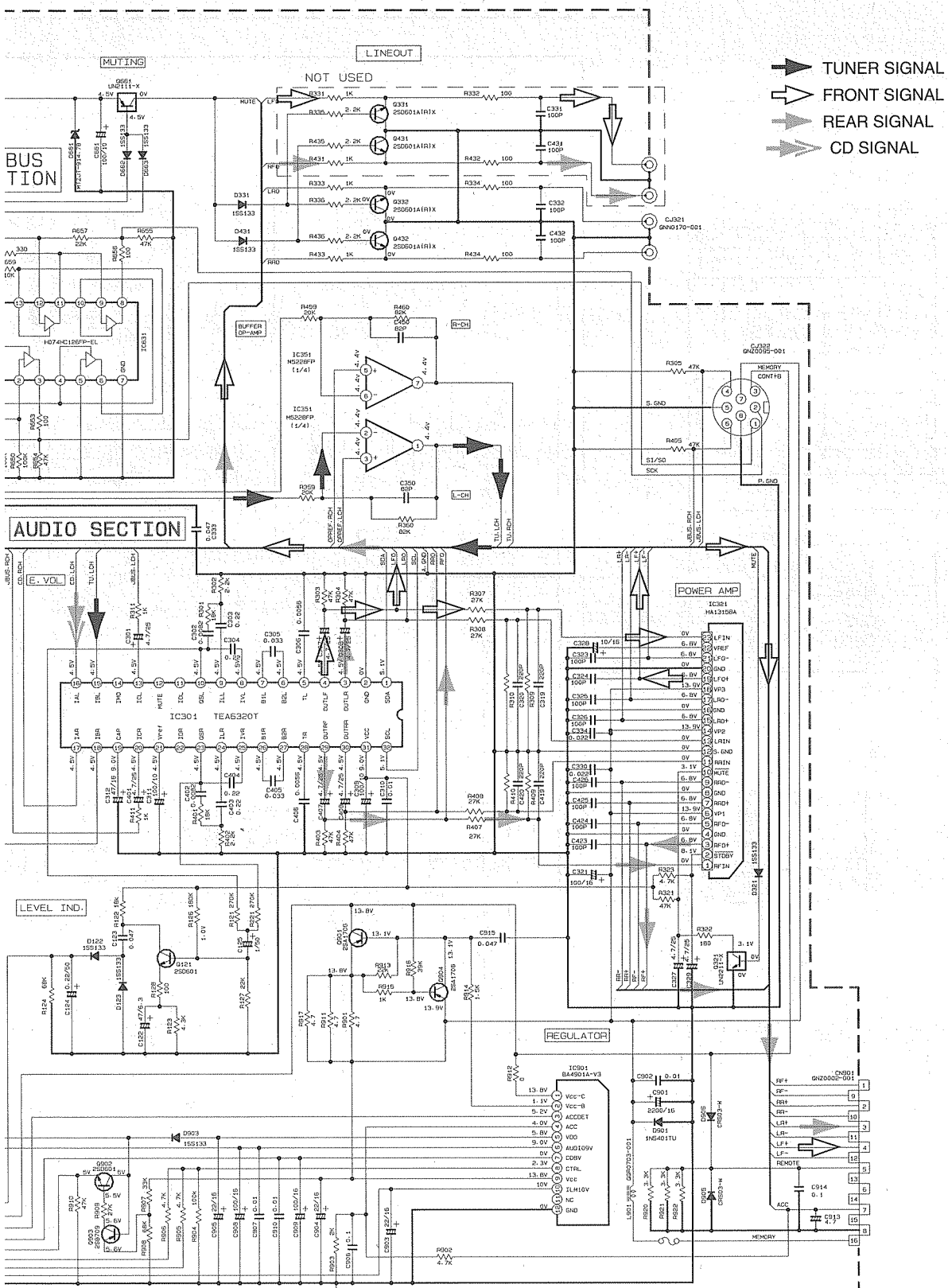

- ▶ TUNER SIGNAL
- ▶ FRONT SIGNAL
- ▶ REAR SIGNAL
- ▶ CD SIGNAL

REMARKS	C709, C710	R191, R201	R192, R202	G01
V. VERSION	0.027	3.0K	4.3K	NOT USED
U. VERSION	0.032	2K	5.6K	USED

NOTES:  
 1. VOLTAGES ARE DC-MEASURED WITH A DIGITAL VOLT METER WITHOUT INPUT SIGNAL.  
 CONDITION --- FM (□) AM MODE

CD control section

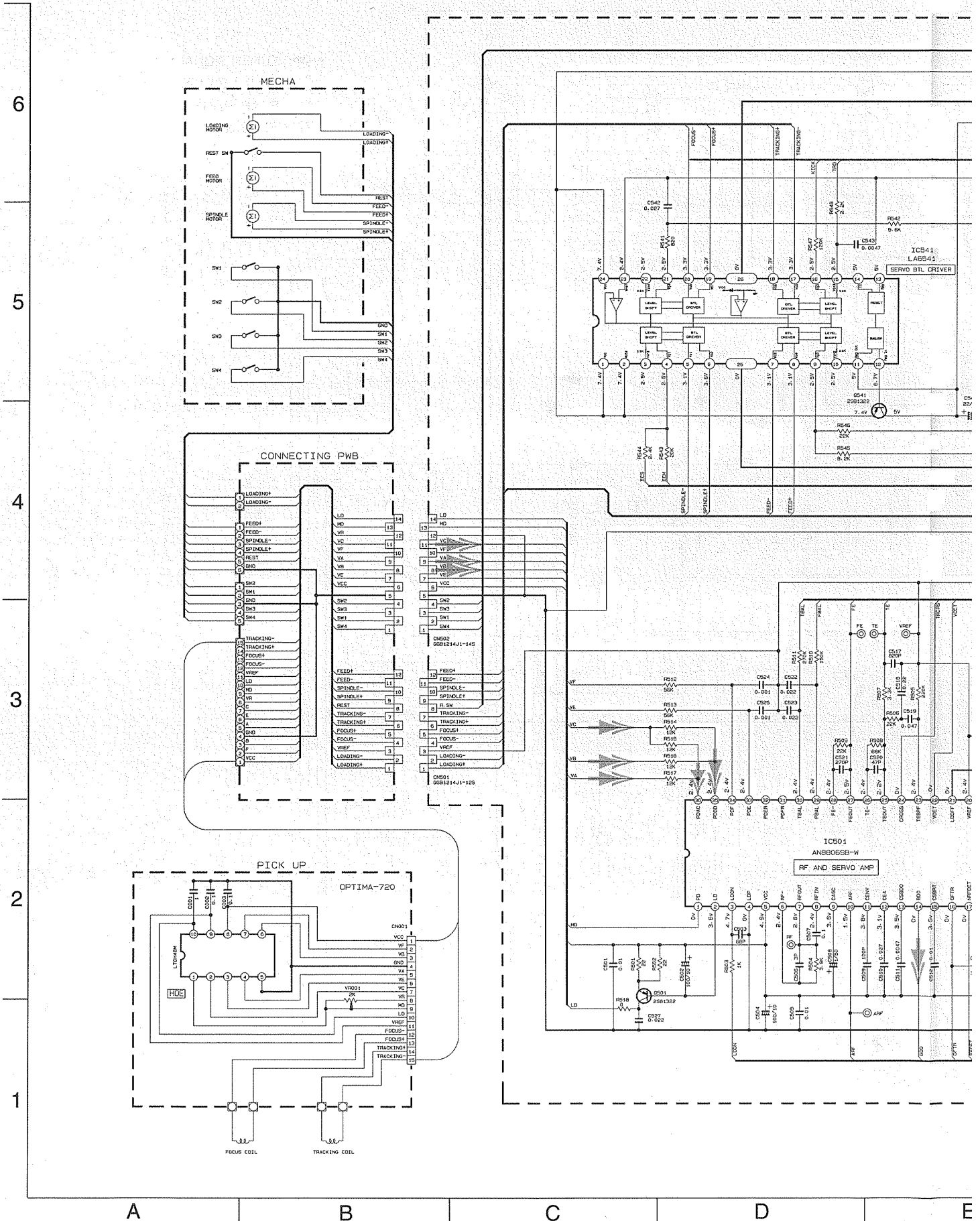

# KD-SX650

## CD SECTION

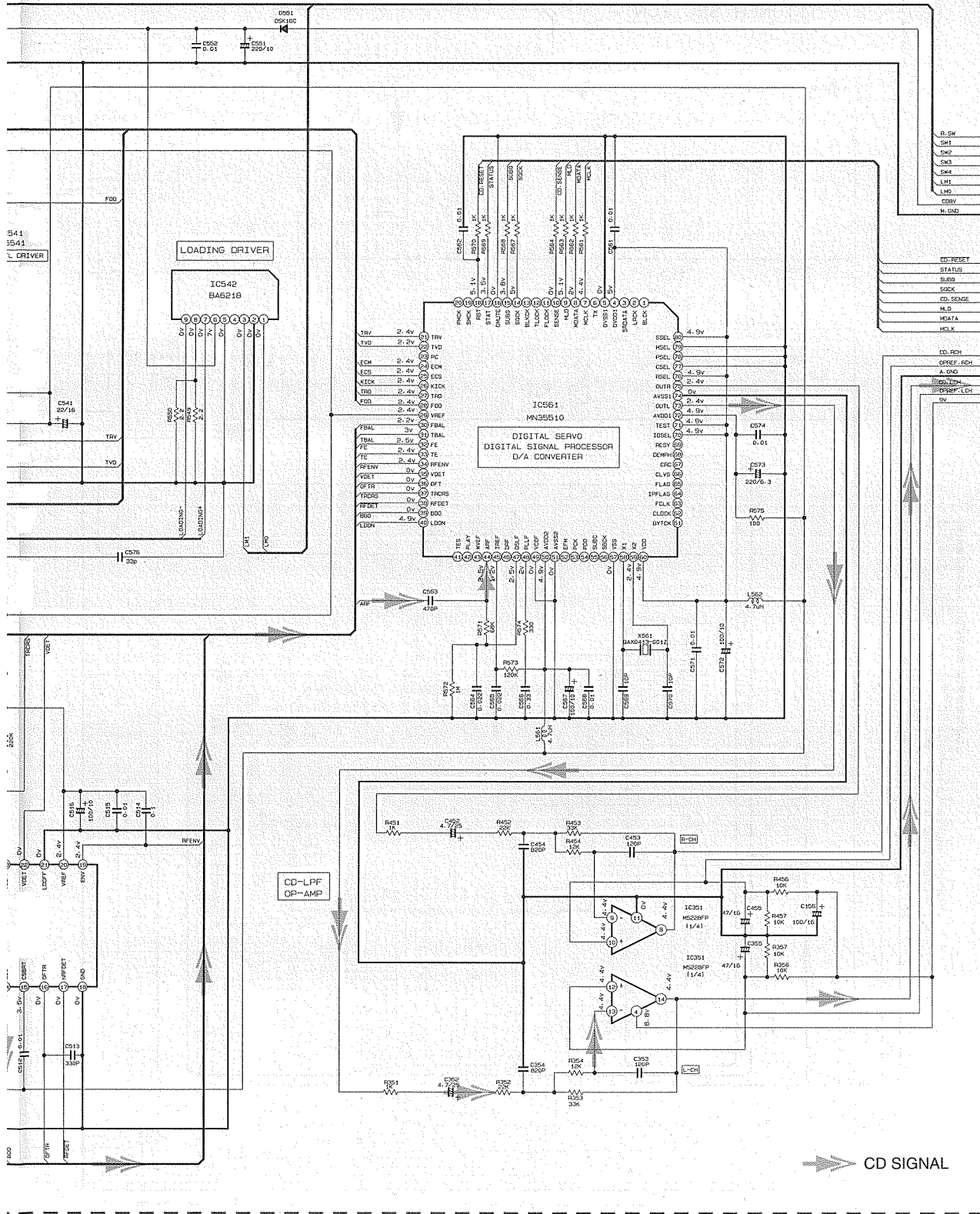

■ FL & Key switch control section

6

5

4

3

2

1

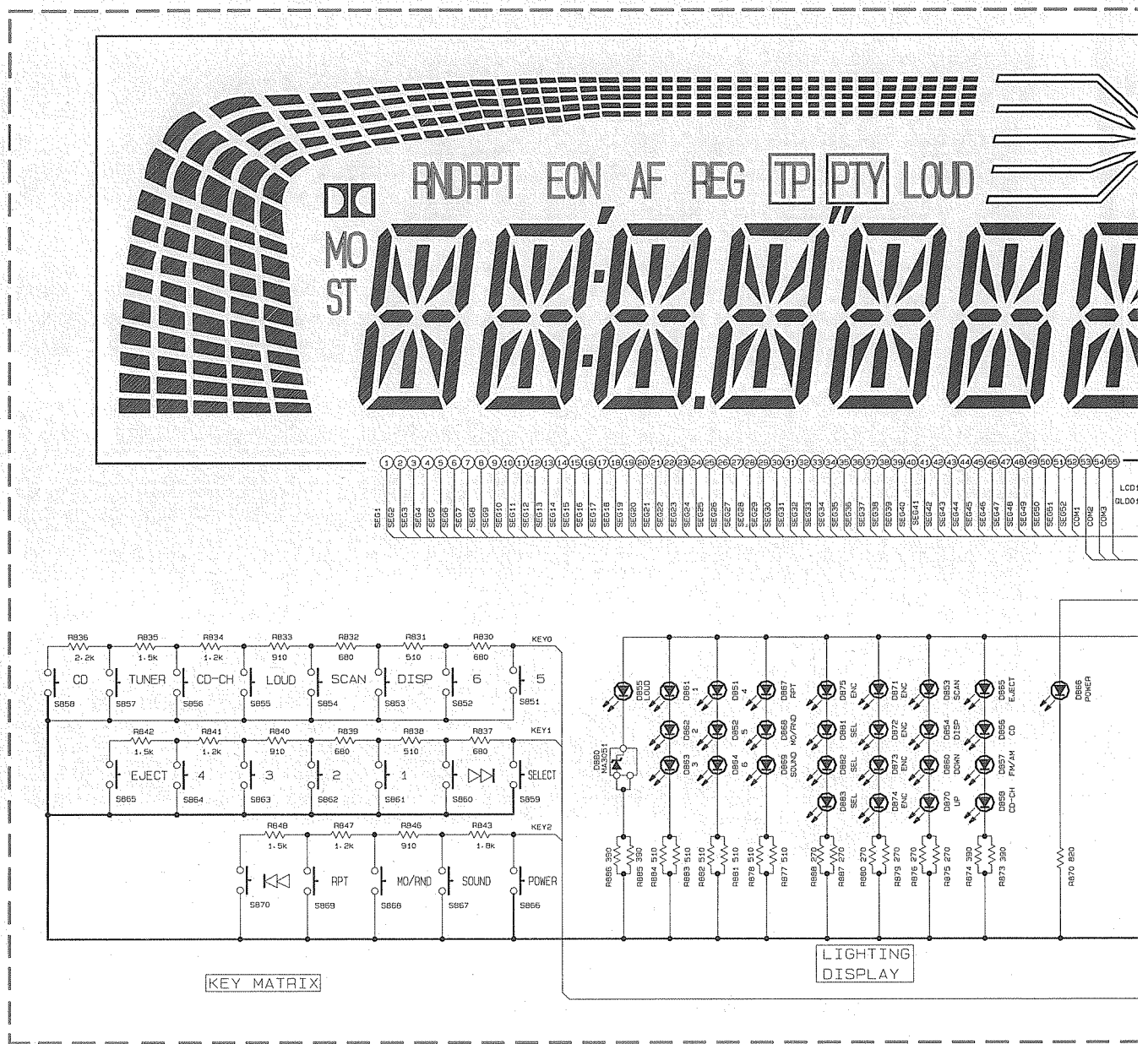

FRONT CIRCUIT BOARD

A

B

C

D

E

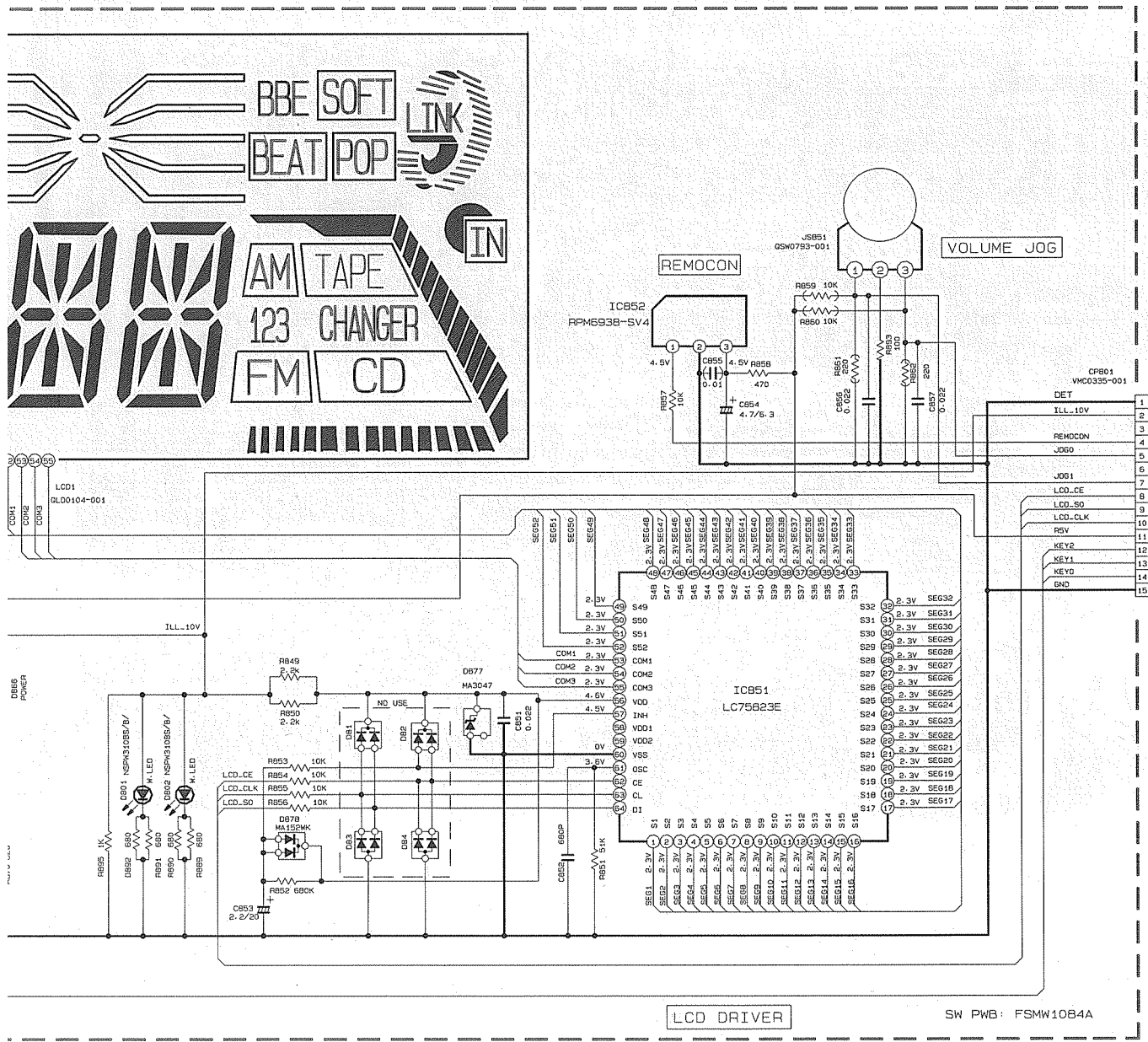

BOARD SECTION

REF. NO.	PART NO.
S851 - S870	NSW0124-001X
DB51 - DB55	LNJ308GB1/1-3/X
DB60 - DB65	
DB67 - DB83	
DB66	SML-310LT/MN/-X
DB56 - DB58	SML-310VT/JK/-X

E F G H I

# Printed circuit boards

■ Main board (Forward side)

KD-SX650

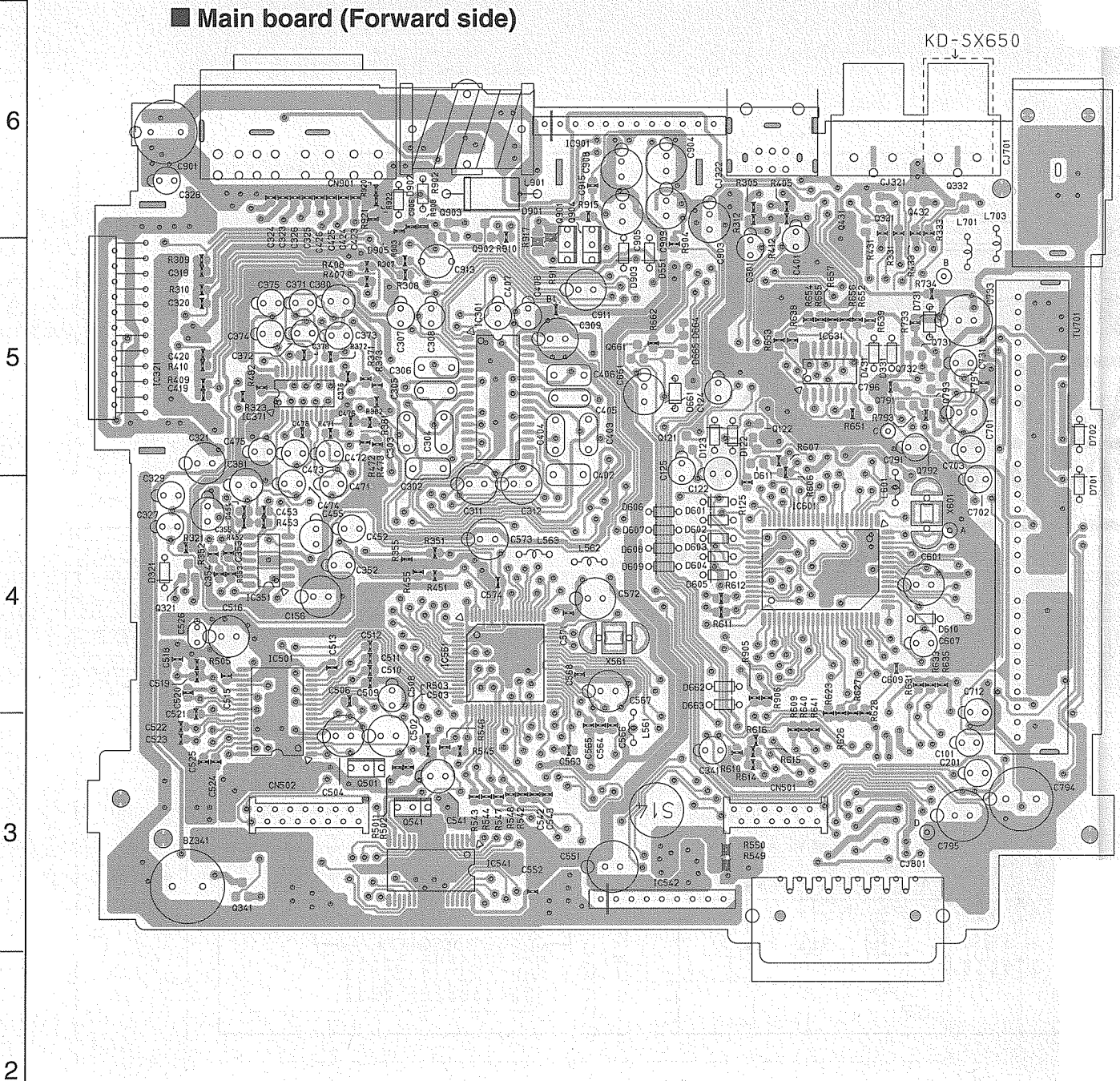

■ Switch board (Forward side)

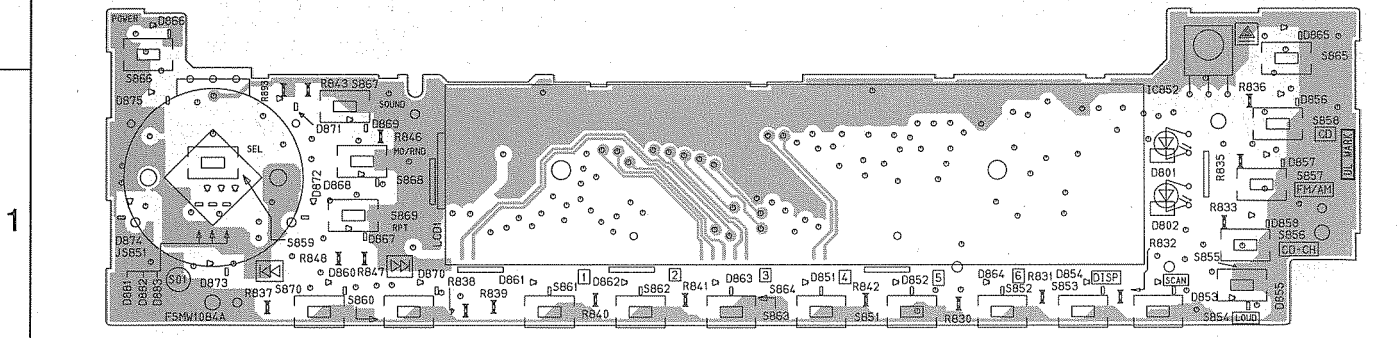

A B C D E



■ Main board (Reverse side)

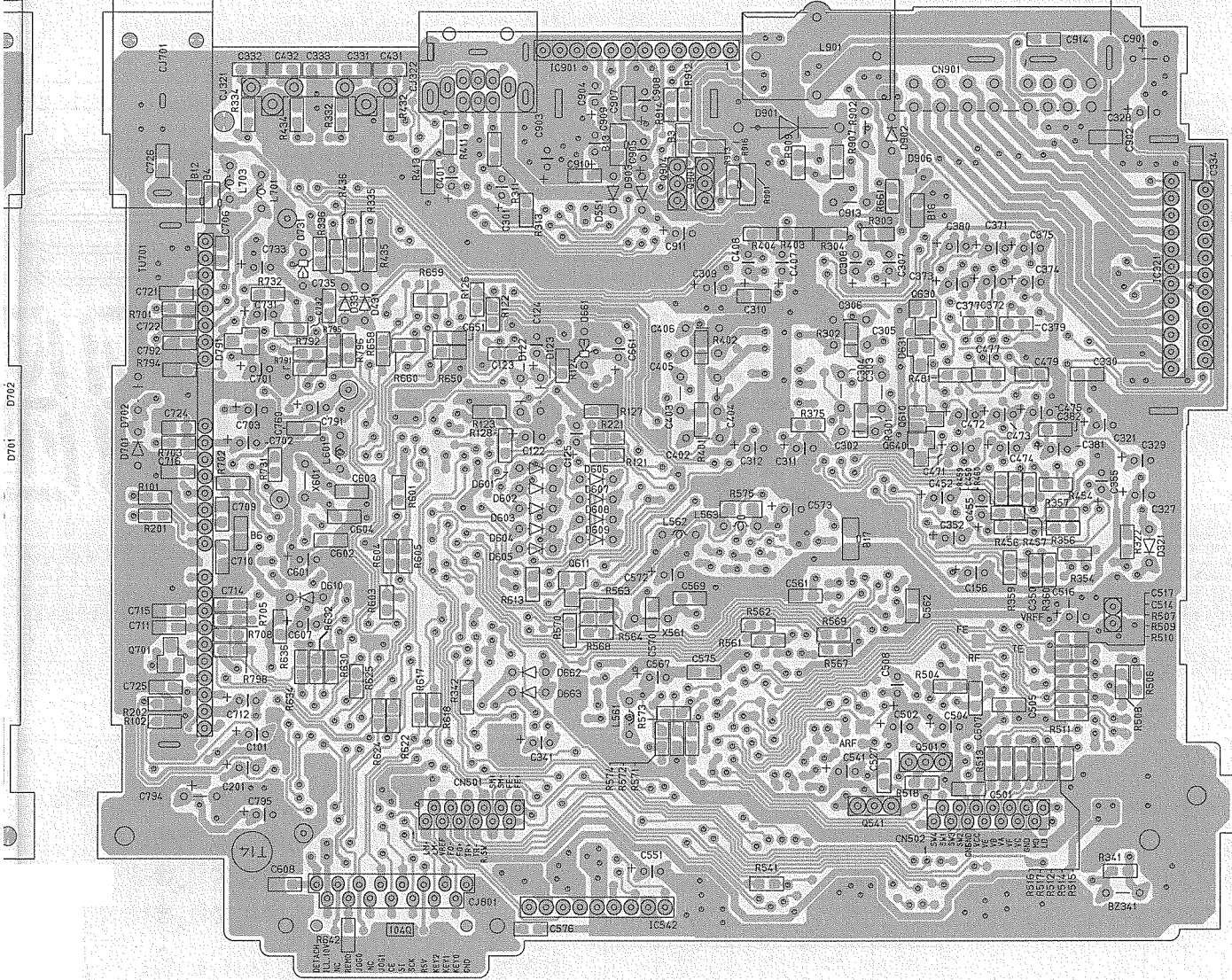

■ Switch board (Reverse side)

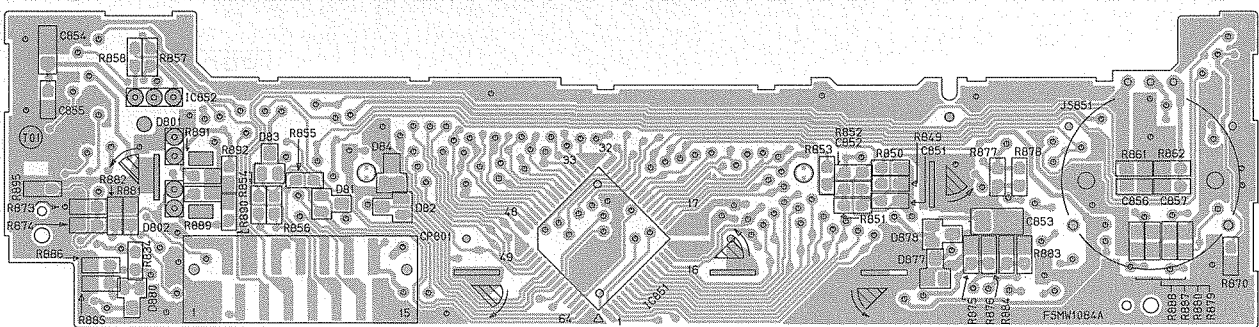



PARTS LIST

[ KD-SX650 ]

\* All printed circuit boards and its assemblies are not available as service parts.

Areas suffix

J ----- U.S.A.

- Contents -

Exploded view of general assembly and parts list .....	3-2
CD mechanism assembly and parts list .....	3-4
Electrical parts list .....	3-6
Packing materials and accessories parts list .....	3-11

■ Parts list (General assembly)

BLOCK NO. <span style="border: 1px solid black; padding: 0 5px;">M1111</span>						
REF.	PARTS NO.	PARTS NAME	REMARKS	QTY	SUFFIX	CLR
1	ZCKDSX650J-NPA	NOSE PIECE	1-1,1-2	1		
2	FSJC1029-021	TOP CHASSIS		1		
3	FSMH3001-202	SIDE PANEL		1		
4	FSKM3011-002	BOTTOM COVER		1		
5	FSMA3004-003	INSULATOR		1		
6	QYSDST2604Z	SCREW	CHASSIS+MECHA B	3		
7	FSKZ4005-001	SCREW		3		
8	QYSDST2606Z	SCREW	CHASSIS+REAR BK	3		
9	QYSDST2606Z	SCREW	CHASSIS+MAIN PW	2		
11	FSJC2013-002	FRONT CHASSIS		1		
12	FSKS3010-001	LOCK LEVER		1		
13	FSKW4005-003	TORSION SPRING	FOR LOCK LEVER	1		
14	FSXP3026-002	RLS KNOB		1		
15	FSKW3002-015	COMP. SPRING		1		
16	FSPK3009-001	BLIND		1		
17		CD MECHA	CHINA M.,M'SIA	1		
21	FSXP2035-031	PRESET BUTTON	1-6, DISP, SCAN	1		
22	FSXP3053-002	POWER BUTTON		1		
23	FSXP3054-001	EJECT BUTTON		1		
24	FSXP4005-015	BBE BUTTON	LOUD	1		
25	FSXP2037-038	PUSH BUTTON	SCM, MO/RND, RPT	1		
26	FSXP2034-033	OPERAT BUTTON	CD, TUNER, CD-CH	1		
27	FSXP3061-001	SEL BUTTON		1		
28	FSXK3003-005	VOL. KNOB	JOG DIAL	1		
29	FSJK3027-001	RIM LENS		1		
30	FSXP3055-001	DETACH BUTTON		1		
31	FSKW3002-012	COMP. SPRING	FOR DETACH BUTT	1		
32	FSJK3026-001	CD LENS		1		
33	FSJC1043-002	REAR COVER		1		
34	VKZ4777-001	MINI SCREW	FRONT+REAR	4		
35	FSYN3103-D006	NAME PLATE		1		
40	QMFZ021-100-J1	FUSE		1		
41	VMA4652-001SS	EARTH PLATE		1		
42	QLD0104-001	LCD MODULE		1		
43	FSYH3018-001	LCD CASE		1		
44	FSJK3025-001	LCD LENS		1		
45	FSKS3012-001	LENS CASE		1		
46	QNZ0443-001	RUBBER CONNE		1		
47	FSKS3016-002	L.E.D.HOLDER		1		
48	FSYH4079-001	LIGHT SHEET		1		
51	FSKM3010-011	REAR BRACKET		1		
52	FSKL4018-00B	IC BRACKET		1		
53	FSKL4015-003	REG. BRACKET		1		
54	QYSDST2606Z	SCREW	FOR ANT	1		
55	QYSDST2606Z	SCREW	16P & REG BKT	3		
56	QYSDSF3006Z	SCREW	FOR LINE OUT	1		
57	FSKL4014-001	HEAT SINK		1		
58	FSYH4059-001	LIGHTING SHEET		1		
59	QYSDST2606Z	SCREW	FOR CH CONN	1		
60	FSYH4036-031	SHEET	PRESET BTN	1		
61	FSYH4036-032	SHEET	SEL BTN	1		
1-1	FSJC1042-002	FRONT PANEL		1		
1-2	FSJD3025-00A	FINDER LENS	NEW PRINTING	1		



# Exploded view of general assembly and parts list

Block No. M 1 M M

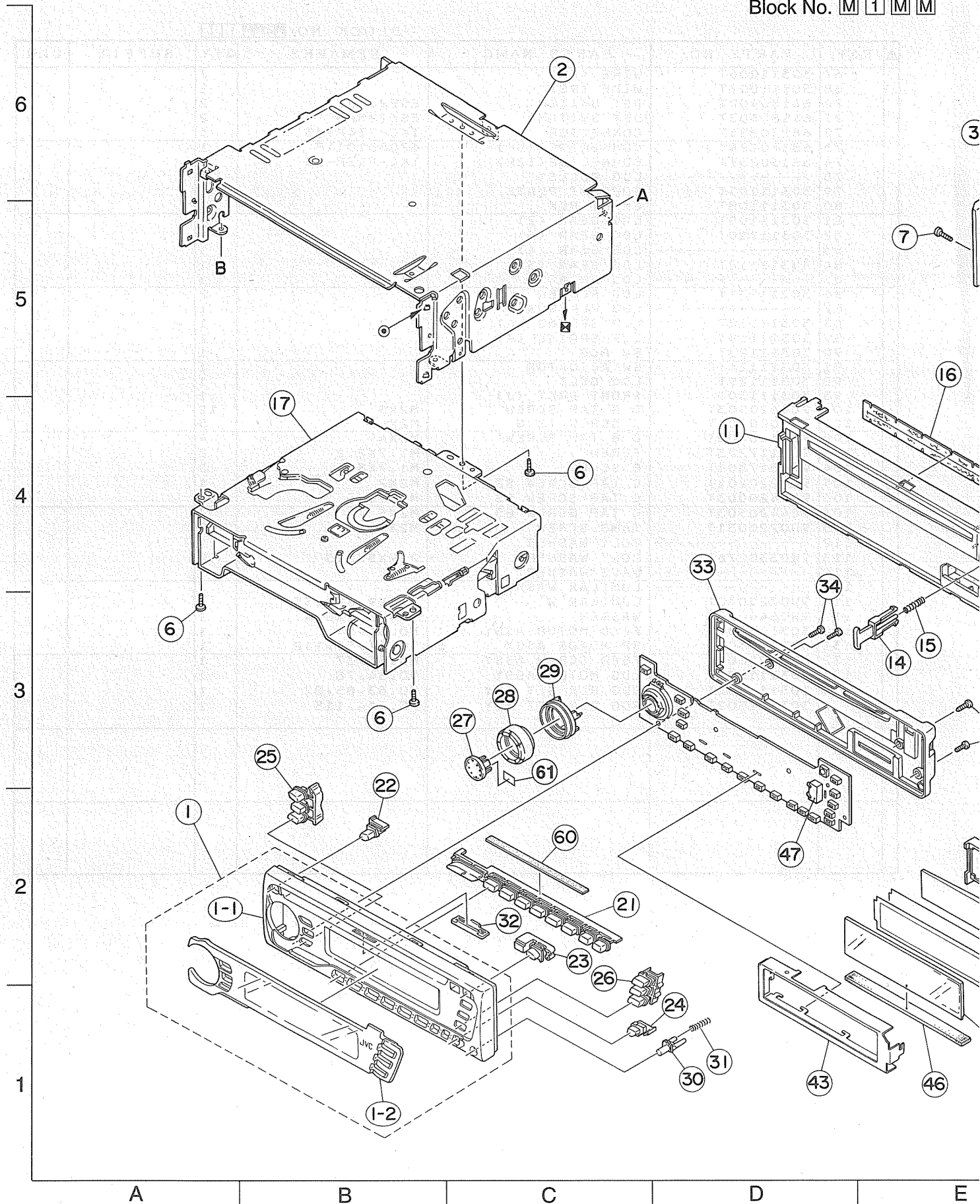

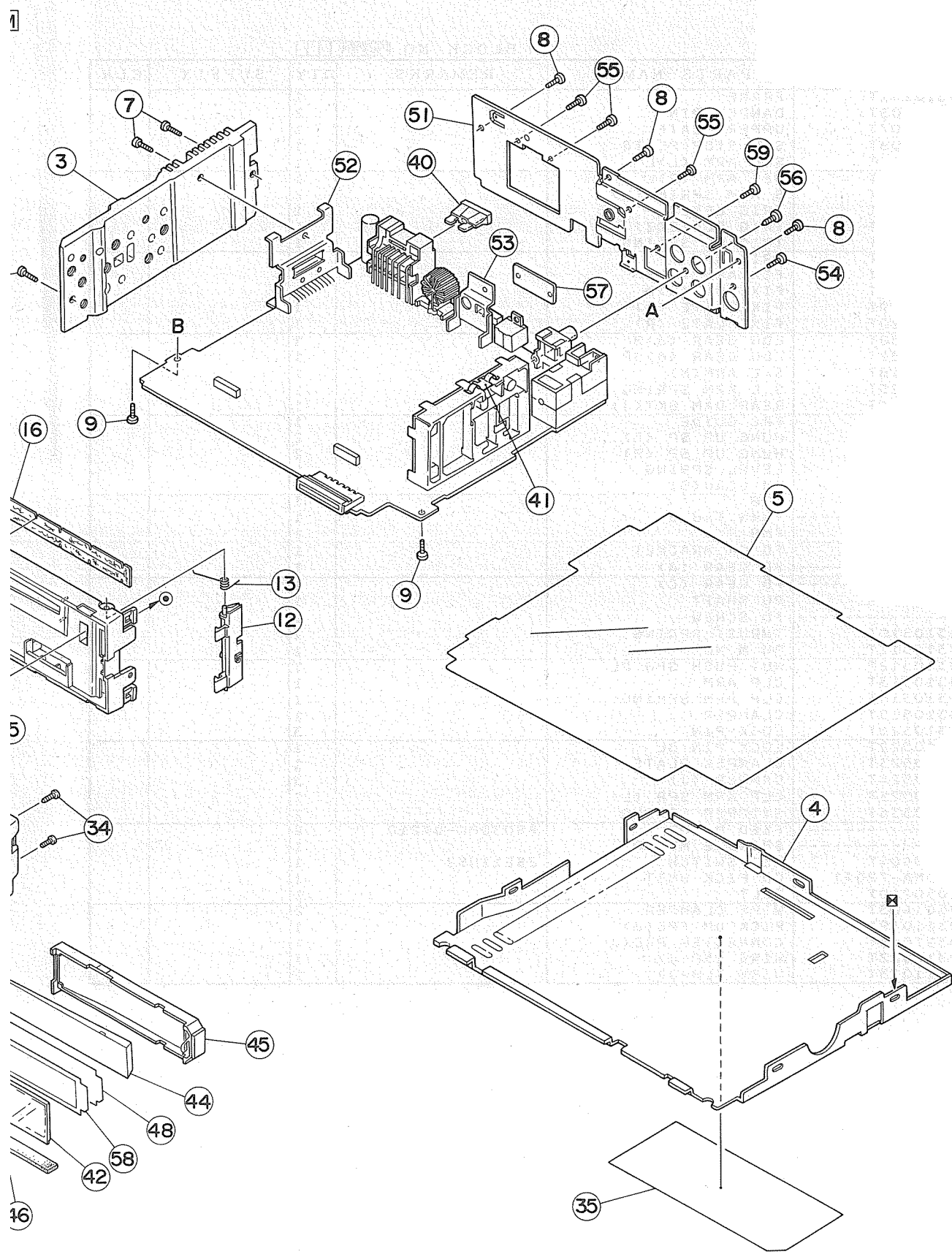

E F G H I

### ■ Parts list (CD mechanism)

BLOCK NO. 

△	REF.	PARTS NO.	PARTS NAME	REMARKS	QTY	SUFFIX	CLR
	1	30310101T	FRAME		1		
	2	30310103T	DANPER PIN		2		
	3	30310107T	UPPER PLATE		1		
	4	30310108T	SEL STOP PLATE		1		
	5	30310142T	SEL ARM (L)L		1		
	6	30310143T	SEL ARM (R)L		1		
	7	30310145T	S ARM SPRING(L)		2		
	8	30310112T	TRIG LEVER		1		
	9	30310155T	TRIG PLATE(Z)		1		
	10	30310115T	TRIG PL SPRING		1		
	11	30310116T	TRIG ARM		1		
	12	30310134T	FIX ARM (L)B		1		
	13	30310135T	FIX ARM (R)B		1		
	14	30310119T	FIX PLATE (L)		1		
	15	30310120T	FIX PLATE (R)		1		
	16	30310138T	LDG GEAR (6)B		1		
	17	30310122T	LDG GEAR (6)SP		1		
	18	30310148T	S.L ARM(N)		1		
	19	30310125T	S.L ARM SPRING		1		
	20	30310126T	REAR DAM BKT(J)		1		
	21	30310127T	FPC GUIDE		1		
	22	30310128T	HUNG UP SP (F)		2		
	23	30310129T	HUNG UP SP (R)		2		
	24	30310130T	LEVEL SPRING		1		
	29	30300510T	PU GEAR(B)		1		
	30	30310501T	TTB		1		
	31	-----	TURN TABLE		1		
	32	30310503T	FMB		1		
	33	30310504T	FD GR BRACKET		1		
	34	-----	FD GEAR (A)		1		
	35	-----	FD GEAR (C)		1		
	36	30310538T	PU SHAFT		1		
	37	-----	FD SCREW		1		
	38	30310510T	THRUST SPRING		1		
	39	30310511T	PU M NUT		1		
	40	30310512T	NUT PUSH SPR PL		1		
	41	30310513T	CLP ARM		1		
	42	30310514T	CLP ARM SPRING		1		
	43	30310515T	CLAMPER		1		
	46	30310521T	LOCK PIN		3		
	47	30310522T	LOCK PIN BL		1		
	48	30310523T	CLAMPER PLATE		1		
	49	30310524T	DAMPER (J)		3		
	50	30310525T	CLP ARM SPR (L)		1		
	51	30310536T	STOPPER SPRING		1		
	54	-----	FEED MOTOR	FF030PK-09210	2		
	55	-----	SPINDLE MOTOR		1		
	56	64180404T	DET SWITCH	ESE11HS2	1		
	57	OPTIMA-720A1	CD PICK UNIT		1		
	61	11050210T	FELT		1		
	62	19501403T	WIRE CLAMPER		2		
	63	30311019T	PICK UP FPC(J)		1		
	64	30311018T	CONNECTER PCB(J)		1		
	65	30311022T	WIRE (5P-J)		1		
	66	30311023T	WIRE (LD-J)		1		



BLOCK NO. M2MM        

△ REF.	PARTS NO.	PARTS NAME	REMARKS	QTY	SUFFIX	CLR
67	30311006T	WIRE (FD)		1		
68	30311007T	WIRE (RS)		1		
70	64180402T	DET SWITCH	ESE22MH1	2		
71	64180403T	DET SWITCH	ESE22MH3	2		
72	68150235T	CONNECTOR	TKC-F14P-J3	1		
73	68170224T	CONNECTOR(15P)	6208010115	1		
74	68150237T	CONNECTOR(12P)	TKC-F12P-J3	1		
78	-----	LDG PULLEY		1		
79	30311105T	SOPPORT PLATE		1		
80	30311108T	GR MT BLK		1		
81	30311109T	LDG GEAR (2)		1		
82	30311110T	LDG GEAR (3)		1		
83	-----	LDG GEAR (4)		1		
84	30311112T	LDG GEAR (5)		1		
85	-----	LDG GR ARM		1		
86	30311131T	LDG ROLLER		2		
87	-----	LDG RLR SHAFT		1		
88	30311118T	L.P SPRING (L)		1		
89	30311119T	L.P SPRING (R)		1		
90	30311123T	SW PCB		1		
91	30311124T	SW ACTUATOR		1		
92	30311129T	LDG BELT		1		
93	30311130T	FRONT BRKT (J)		1		
100	9C0620503T	C B TAP SCREW	M2X5	12		
101	9C2020401T	C SCREW TS.G	M2X4	5		
102	9C4320403T	C B TAP SCREW	M2X4	4		
103	9C0117223T	SCREW	M1.7X2.2	2		
104	9C0317803T	C SCREW	M1.7X8	2		
105	9C4220201T	C TAP SCREW S3	M2X2	1		
106	9C4420003T	C TAP SCREW B3	M2X10	1		
107	9C4420503T	C TAP SCREW B3	M2X5	2		
108	9P0220031T	TAMS SCREW	M2X3	2		
112	-----	POLY WASHER		1		
113	9W0330276T	POLY WASHER	2.9X5X0.3	2		
114	-----	WAVE WASHER		1		
115	-----	LUMILAR WASHER		1		
116	9W0725030T	LUMILAR W	2.3X9.8X0.35	1		
117	9W0640030T	WASHER	1.4X3.2X0.4	1		
130	303105301T	FFED MOTOR ASSY	NO.34,54	1		
131	303105302T	SP MOTOR ASSY	NO.31,55,112	1		
132	303105303T	FEED SCREW ASSY	NO.35,37	1		
133	303111301T	LDG MOTOR ASSY	NO.54,78	1		
134	303111302T	RDG RLR SFT ASY	NO.83,85,87	1		
	303111302T	RDG RLR SFT ASY	NO.114,115	1		



# CD mechanism assembly and parts list

KD-LX1JD(MA2)

Block No. M 2 M M

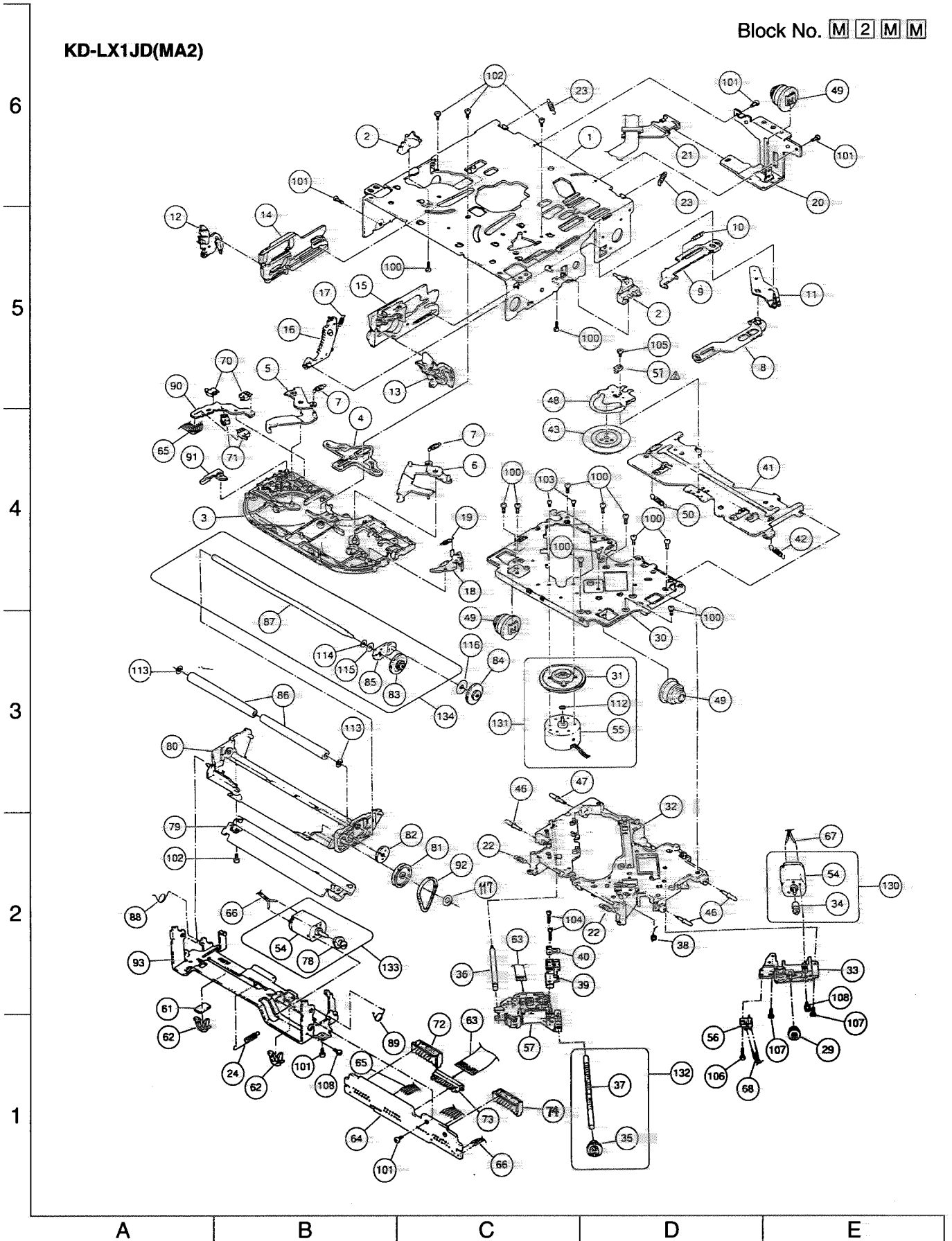

# Electrical parts list

**Main board**

BLOCK NO. 01111111		BLOCK NO. 01111111			
A	REF.	PARTS NO.	PARTS NAME	REMARKS	SUFFIX
	C 101	GEK41HM-105	E CAPACITOR	1.0MF 20X 50V	
	C 122	GEKJ1M-4762	E CAPACITOR	47MF 20X 6.3V	
	C 123	NCB21EK-475X	C CAPACITOR		
	C 124	GEK41HM-824	E CAPACITOR		
	C 125	GEK41HM-105	E CAPACITOR	-22MF 20X 50V	
	C 154	GEKJ1CM-107Z	E CAPACITOR	100MF 20X 16V	
	C 201	GEK41HM-105	E CAPACITOR	1.0MF 20X 50V	
	C 301	GEK41EM-875	E CAPACITOR	4.7NF 20X 25V	
	C 302	FLA11HJ-852Z	M CAPACITOR	8200PF 5X 50V	
	C 303	GFV41HJ-824	TF CAPACITOR	-22MF 5X 50V	
	C 304	GFV41HJ-224	TF CAPACITOR	-22MF 5X 50V	
	C 305	GFV41HJ-323	TF CAPACITOR	-033MF 5X 50V	
	C 306	FLA11HJ-562Z	M CAPACITOR	5600PF 5X 50V	
	C 307	GEK41EM-475	E CAPACITOR	4.7NF 20X 25V	
	C 308	GEK41EM-475	E CAPACITOR	4.7NF 20X 25V	
	C 309	GEKJ1AM-107Z	E CAPACITOR	100NF 20X 10V	
	C 310	NCB21HK-105X	C CAPACITOR		
	C 311	GEKJ1AM-107Z	E CAPACITOR	100NF 20X 10V	
	C 312	GEK41CM-476	E CAPACITOR	47MF 20X 16V	
	C 319	NCB21HJ-221X	C CAPACITOR		
	C 320	NCB21HJ-221X	C CAPACITOR		
	C 321	GEKJ1CM-107Z	E CAPACITOR	100MF 20X 16V	
	C 327	GEK41EM-475	E CAPACITOR	4.7NF 20X 25V	
	C 328	GEK41CM-106	E CAPACITOR	10MF 20X 16V	
	C 329	GEK41EM-106	E CAPACITOR	10MF 20X 16V	
	C 330	GEK41EM-475	E CAPACITOR	4.7NF 20X 25V	
	C 330	NCB21HK-223X	C CAPACITOR		
	C 332	NCB21HJ-101X	C CAPACITOR		
	C 333	NCB21EK-475X	C CAPACITOR		
	C 334	NCB21HK-223X	C CAPACITOR		
	C 350	NCB21HJ-820X	C CAPACITOR		
	C 352	GEK41EM-475	E CAPACITOR	4.7NF 20X 25V	
	C 353	NCB21HJ-121X	C CAPACITOR		
	C 354	NCB21HJ-821X	C CAPACITOR		
	C 355	GEK41CM-476	E CAPACITOR	47MF 20X 16V	
	C 401	GEK41EM-475	E CAPACITOR	4.7NF 20X 25V	
	C 402	FLA11HJ-822Z	M CAPACITOR	8200PF 5X 50V	
	C 403	GFV41HJ-224	TF CAPACITOR	-22MF 5X 50V	
	C 404	GFV41HJ-224	TF CAPACITOR	-22MF 5X 50V	
	C 405	GFV41HJ-323	TF CAPACITOR	-033MF 5X 50V	
	C 406	FLA11HJ-562Z	M CAPACITOR	5600PF 5X 50V	
	C 407	GEK41EM-475	E CAPACITOR	4.7NF 20X 25V	
	C 408	GEK41EM-475	E CAPACITOR	4.7NF 20X 25V	
	C 419	NCB21HJ-221X	C CAPACITOR		
	C 420	NCB21HJ-221X	C CAPACITOR		
	C 432	NCB21HJ-101X	C CAPACITOR		
	C 450	NCB21HJ-820X	C CAPACITOR		
	C 452	GEK41EM-475	E CAPACITOR	4.7NF 20X 25V	
	C 453	NCB21HJ-121X	C CAPACITOR		
	C 454	NCB21HJ-821X	C CAPACITOR		
	C 455	GEK41CM-476	E CAPACITOR	47MF 20X 16V	
	C 501	NCB21EK-105X	C CAPACITOR		
	C 502	GEKJ1AM-107Z	E CAPACITOR	100NF 20X 10V	
	C 503	NCB21HJ-60X	E CAPACITOR	100NF 20X 10V	
	C 504	GEKJ1AM-107Z	E CAPACITOR	100NF 20X 10V	
	C 505	NCB21EK-105X	C CAPACITOR		
	C 506	NDC21HJ-320X	C CAPACITOR		
	C 507	NCB21EK-104X	C CAPACITOR		
	C 508	GEK41HM-105	E CAPACITOR	1.0MF 20X 50V	
	C 509	NDC21HJ-101X	C CAPACITOR		
	C 510	NCB21HK-223X	C CAPACITOR		
	C 511	NCB21HK-105X	C CAPACITOR		
	C 512	NCB21HK-105X	C CAPACITOR		
	C 513	NDC21HJ-321X	C CAPACITOR		
	C 514	NCB21EK-104X	C CAPACITOR		
	C 515	NCB21EK-105X	C CAPACITOR		
	C 516	GEKJ1AM-107Z	E CAPACITOR	100MF 20X 10V	
	C 517	NCB21HJ-821X	C CAPACITOR		
	C 518	NCB21EK-224X	C CAPACITOR		
	C 519	NCB21EK-475X	C CAPACITOR		
	C 520	NDC21HJ-470X	C CAPACITOR		
	C 521	NCB21HJ-221X	C CAPACITOR		
	C 522	NCB21HK-223X	C CAPACITOR		
	C 523	NCB21HK-223X	C CAPACITOR		
	C 524	NCB21HK-102X	C CAPACITOR		
	C 525	NCB21HK-102X	C CAPACITOR		
	C 527	NCB21EK-223X	C CAPACITOR		
	C 541	GEK41CM-224	E CAPACITOR	22MF 20X 16V	
	C 542	NCB21HK-223X	C CAPACITOR		
	C 543	NCB21HK-472X	C CAPACITOR		
	C 545	NCB21HK-472X	C CAPACITOR		
	C 552	GEK41EM-227	E CAPACITOR	220MF 20X 10V	
	C 552	NCB21EK-105X	C CAPACITOR		
	C 561	NCB21EK-105X	C CAPACITOR		
	C 562	NCB21EK-105X	C CAPACITOR		
	C 563	NCB21HK-471X	C CAPACITOR		
	C 564	NCB21HK-223X	C CAPACITOR		
	C 565	NCB21HK-223X	C CAPACITOR		
	C 566	NCB21EK-324X	C CAPACITOR		
	C 567	GEKJ1AM-107Z	E CAPACITOR	100MF 20X 10V	
	C 568	NCB21EK-105X	C CAPACITOR		
	C 569	NDC21HJ-100X	C CAPACITOR		
	C 570	NDC21HJ-100X	C CAPACITOR		
	C 571	NCB21EK-105X	C CAPACITOR		
	C 572	GEKJ1AM-107Z	E CAPACITOR	100MF 20X 10V	
	C 573	GEK40JM-227	E CAPACITOR	220MF 20X 6.3V	
	C 574	NCB21EK-105X	C CAPACITOR		
	C 576	NDC21HJ-320X	C CAPACITOR		
	C 601	GEK40JM-227	E CAPACITOR	220MF 20X 6.3V	
	C 602	NCB21EK-105X	C CAPACITOR		
	C 603	NDC21HJ-220X	C CAPACITOR		
	C 604	NDC21HJ-320X	C CAPACITOR		
	C 607	GEK41EM-106	E CAPACITOR	10MF 20X 16V	
	C 608	NCB21EK-104X	C CAPACITOR		
	C 609	NCB21EK-823X	C CAPACITOR		
	C 651	NCB21EK-105X	C CAPACITOR		
	C 641	GEKJ1AM-107Z	E CAPACITOR	100MF 20X 10V	
	C 701	GEKJ1CM-107Z	E CAPACITOR	100MF 20X 16V	
	C 702	GEK41HM-104	E CAPACITOR	.10MF 20X 50V	
	C 703	GEK41HM-104	E CAPACITOR	.10MF 20X 50V	
	C 709	NCB21HK-275X	C CAPACITOR		
	C 710	NCB21HK-275X	C CAPACITOR		

REF.	PARTS NO.	PARTS NAME	REMARKS	SUFFIX
C 711	NCB21CK-224X	C CAPACITOR		
C 712	GK41HK-104	E CAPACITOR	.10MF 20X 50V	
C 714	NC521HJ-121X	C CAPACITOR		
C 716	NC211HJ-150X	C CAPACITOR		
C 731	GR641HM-226	E CAPACITOR	2.2MF 20X 50V	
C 732	NCB21HK-102X	C CAPACITOR		
C 733	GR41AM-221	E CAPACITOR	220MF 20X 10V	
C 735	NC211HJ-330X	C CAPACITOR		
C 760	NC521HJ-560X	C CAPACITOR		
C 791	GK41CM-106	E CAPACITOR	10MF 20X 16V	
C 792	NCB21HK-223X	C CAPACITOR		
C 794	GR41CM-477	E CAPACITOR	470MF 20X 16V	
C 901	GR20337-228	E CAPACITOR	2200MF	
C 902	NCB21HK-103X	C CAPACITOR		
C 903	GK41CM-226	E CAPACITOR	22MF 20X 16V	
C 904	GK41CM-226	E CAPACITOR	22MF 20X 16V	
C 905	GK41CM-226	E CAPACITOR	22MF 20X 16V	
C 906	NCB21HK-104X	C CAPACITOR		
C 907	NCB21HK-103X	C CAPACITOR		
C 908	GK11CM-107Z	E CAPACITOR	100MF 20X 16V	
C 909	GK11CM-107Z	E CAPACITOR	100MF 20X 16V	
C 910	NCB21HK-103X	C CAPACITOR		
C 911	GR40JM-227	E CAPACITOR	220MF 20X 6.3V	
C 913	GR661M-472	NP E CAPACITOR	4.7MF 20X 25V	
C 914	NCB21HK-104X	C CAPACITOR		
C 915	NCB21HK-473X	C CAPACITOR		
CJ321	QNO170-001	PIN JACK (REEL)		
CJ322	QNZ0095-001	CONNECTOR		
CJ701	QNZ0095-001	CAR ANT JACK		
CJ801	QVC0334-001	CONNECTOR		
CN501	GB121411-125	CONNECTOR		
CN502	GB121411-145	CONNECTOR		
CN901	QZ70002-001	16P CONNECTOR		
D 152	1S133-T1	SI DIODE I/M		
D 153	1S133-T1	SI DIODE I/M		
D 321	1S133-T1	SI DIODE I/M		
D 331	1S133-T1	SI DIODE I/M		
D 431	1S133-T1	SI DIODE I/M		
D 531	DK10C-T1	DIODE		
D 605	1S133-T1	SI DIODE I/M		
D 610	1S133-T1	SI DIODE I/M		
D 661	M72J4-7B-T1	ZENER DIODE		
D 662	1S133-T1	SI DIODE I/M		
D 663	1S133-T1	SI DIODE I/M		
D 665	M152HK-X	SI DIODE		
D 701	1S133-T1	SI DIODE I/M		
D 702	1S133-T1	SI DIODE I/M		
D 731	M7110C-T1	ZENER DIODE		
D 791	M152HK-X	SI DIODE		
D 901	1S133-TU-05	DIODE		
D 902	1S133-T1	SI DIODE I/M		
D 903	CR503-W	S8 DIODE		
D 906	CR503-W	S8 DIODE		
IC301	TA6320T-X	IC		
IC321	HA13158A	IC		

REF.	PARTS NO.	PARTS NAME	REMARKS	SUFFIX
IC331	M5228FF-W	IC		
IC501	ANB8065B-W	IC		
IC541	LA6541-X	IC		
IC542	BA6218	IC		
IC561	MM35510	IC		
IC601	LT72366-9594	IC (MICRO-COMP)		
IC631	HP74HC126FP-X	IC		
IC901	BA4901A-V3	IC		
L 501	90L244J-4R7Z	INDUCTOR		
L 502	90L244J-4R7Z	INDUCTOR		
L 601	90L244J-4R7Z	INDUCTOR		
L 701	90L244J-330Z	INDUCTOR		
L 901	GR0703-001	CHOKO COIL		
Q 121	2SD601A/R/-X	TRANSISTOR		
Q 321	UM2211-X	TRANSISTOR		
Q 332	2SD601A/R/-X	TRANSISTOR		
Q 432	2SD601A/R/-X	TRANSISTOR		
Q 501	2SB132/RS/-T	TRANSISTOR		
Q 541	2SB132/RS/-T	TRANSISTOR		
Q 641	UM2111-X	TRANSISTOR		
Q 701	UM2211-X	TRANSISTOR		
Q 711	2SD601A/R/-X	TRANSISTOR		
Q 732	2SD601A/R/-X	TRANSISTOR		
Q 791	2SB1197K/GR/-X	TRANSISTOR		
Q 792	2SB709A/R/-X	TRANSISTOR		
Q 904	2SA1706/ST/-T	TRANSISTOR		
Q 901	2SA1706/ST/-T	TRANSISTOR		
Q 902	2SD601A/R/-X	TRANSISTOR		
Q 903	2SB709A/R/-X	TRANSISTOR		
Q 904	2SA1706/ST/-T	TRANSISTOR		
R 101	NPSA021-392X	MG RESISTOR		
R 102	NPSA021-432X	MG RESISTOR		
R 111	NPSA021-274X	MG RESISTOR		
R 112	NPSA021-184X	MG RESISTOR		
R 113	NPSA021-632X	MG RESISTOR		
R 114	NPSA021-682X	MG RESISTOR		
R 146	NPSA021-184X	MG RESISTOR		
R 147	NPSA021-222X	MG RESISTOR		
R 149	NPSA021-101X	MG RESISTOR		
R 201	NPSA021-392X	MG RESISTOR		
R 202	NPSA021-432X	MG RESISTOR		
R 221	NPSA021-274X	MG RESISTOR		
R 301	NPSA021-222X	MG RESISTOR		
R 302	NPSA021-222X	MG RESISTOR		
R 303	NPSA021-473X	MG RESISTOR		
R 304	NPSA021-473X	MG RESISTOR		
R 305	NPSA021-473X	MG RESISTOR		
R 307	NPSA021-272X	MG RESISTOR		
R 308	NPSA021-272X	MG RESISTOR		
R 311	NPSA021-102X	MG RESISTOR		
R 312	NPSA021-472X	MG RESISTOR		
R 342	NPSA021-181X	MG RESISTOR		
R 343	NPSA021-472X	MG RESISTOR		
R 344	NPSA021-102X	MG RESISTOR		
R 345	NPSA021-101X	MG RESISTOR		



■ Front board

BLOCK NO. 01111111		BLOCK NO. 01111111		
A REF.	PARTS NO.	PARTS NAME	REMARKS	SUFFIX
R 661	NRSA02J-471X	MG RESISTOR		
R 662	NRSA02J-471X	MG RESISTOR		
R 701	NRSA02J-102X	MG RESISTOR		
R 702	NRSA02J-221X	MG RESISTOR		
R 703	NRSA02J-102X	MG RESISTOR		
R 705	NRSA02J-103X	MG RESISTOR		
R 708	NRSA02J-155X	MG RESISTOR		
R 731	NRSA02J-152X	MG RESISTOR		
R 732	NRSA02J-102X	MG RESISTOR		
R 733	NRSA02J-103X	MG RESISTOR		
R 754	NRSA02J-471X	MG RESISTOR		
R 791	NRSA02J-103X	MG RESISTOR		
R 792	NRSA02J-102X	MG RESISTOR		
R 793	NRSA02J-103X	MG RESISTOR		
R 794	NRSA02J-222X	MG RESISTOR		
R 795	NRSA02J-150X	MG RESISTOR		
R 796	NRSA02J-150X	MG RESISTOR		
R 797	NRSA02J-100X	MG RESISTOR		
R 798	NRSA02J-105X	MG RESISTOR		
R 901	NRS103J-872X	MG RESISTOR		
R 902	GRZ0225-472X	C RESISTOR	4.7K 1/1W	
R 903	NRSA02J-202X	MG RESISTOR		
R 904	NRSA02J-104X	MG RESISTOR		
R 905	NRSA02J-472X	MG RESISTOR		
R 906	NRSA02J-472X	MG RESISTOR		
R 907	NRSA02J-323X	MG RESISTOR		
R 908	NRSA02J-623X	MG RESISTOR		
R 909	NRSA02J-223X	MG RESISTOR		
R 910	NRSA02J-473X	MG RESISTOR		
R 911	NRS181J-477X	MG RESISTOR		
R 912	NRSA02J-100X	MG RESISTOR		
R 913	NRSA02J-22X	MG RESISTOR		
R 914	NRSA02J-152X	MG RESISTOR		
R 915	NRSA02J-102X	MG RESISTOR		
R 916	NRSA02J-323X	MG RESISTOR		
R 917	NRS181J-477X	MG RESISTOR		
R 920	NRSA02J-322X	MG RESISTOR		
R 921	NRSA02J-322X	MG RESISTOR		
R 922	NRSA02J-322X	MG RESISTOR		
TU701	CAU0133-001	TUNER		
X 561	GAX0413-001Z	CRYSTAL		
X 601	GAX0406-001Z	CRYSTAL		
A REF.	PARTS NO.	PARTS NAME	REMARKS	SUFFIX
C 851	NCB21HK-223X	C CAPACITOR		
C 852	NCS21HJ-681X	C CAPACITOR		
C 853	NBE41DM-225X	TA E CAPACITOR		
C 854	NBE20JM-475X	TS E CAPACITOR		
C 856	NCB21HK-223X	C CAPACITOR		
C 857	NCB31HK-223X	C CAPACITOR		
C 801	VMC0335-001	CONNECTOR		
D 801	NSPW310BS/B/	LED		
D 802	NSPW310BS/B/	LED		
D 851	LNJ308GB1/1-3/X	LED	"4"	
D 852	LNJ308GB1/1-3/X	LED	"5"	
D 853	LNJ308GB1/1-3/X	LED	"SCAN"	
D 854	LNJ308GB1/1-3/X	LED	"DISP"	
D 855	LNJ308GB1/1-3/X	LED	"LOUD LED"	
D 856	SML-310V1/JK-K	LED	"CD"	
D 857	SML-310V1/JK-K	LED	"FM/AM"	
D 858	SML-310V1/JK-K	LED	"CD-CH"	
D 860	LNJ308GB1/1-3/X	LED	"DOWN"	
D 861	LNJ308GB1/1-3/X	LED	"1"	
D 862	LNJ308GB1/1-3/X	LED	"2"	
D 863	LNJ308GB1/1-3/X	LED	"3"	
D 864	LNJ308GB1/1-3/X	LED	"4"	
D 865	LNJ308GB1/1-3/X	LED	"EJECT"	
D 866	LNJ308GB1/1-3/X	LED	"POWER LED"	
D 867	SML-310L1/MN1-X	LED	"1"	
D 868	LNJ308GB1/1-3/X	LED	"MOTORND"	
D 869	LNJ308GB1/1-3/X	LED	"SOUND"	
D 870	LNJ308GB1/1-3/X	LED	"UP"	
D 871	LNJ308GB1/1-3/X	LED	"ENC"	
D 872	LNJ308GB1/1-3/X	LED	"ENC"	
D 873	LNJ308GB1/1-3/X	LED	"ENC"	
D 874	LNJ308GB1/1-3/X	LED	"ENC"	
D 875	LNJ308GB1/1-3/X	LED	"ENC"	
D 877	MA3047/MY-X	ZENER DIODE		
D 878	MA1524K-X	S DIODE		
D 880	MA3047/MY-X	ZENER DIODE		
D 881	LNJ308GB1/1-3/X	LED	"SEL"	
D 882	LNJ308GB1/1-3/X	LED	"SEL"	
D 883	LNJ308GB1/1-3/X	LED	"SEL"	
I 6851	LC75523E	IC		
I 6852	RPM695B-SV4	IC		
J 8851	OSW0793-001	ROTARY ENCODER		
R 830	NRSA02J-681X	MG RESISTOR		
R 831	NRSA02J-511X	MG RESISTOR		
R 832	NRSA02J-681X	MG RESISTOR		
R 833	NRSA02J-911X	MG RESISTOR		
R 834	NRSA02J-122X	MG RESISTOR		
R 835	NRSA02J-152X	MG RESISTOR		
R 836	NRSA02J-222X	MG RESISTOR		
R 837	NRSA02J-681X	MG RESISTOR		
R 838	NRSA02J-511X	MG RESISTOR		
R 839	NRSA02J-681X	MG RESISTOR		
R 840	NRSA02J-911X	MG RESISTOR		
R 841	NRSA02J-122X	MG RESISTOR		
R 842	NRSA02J-152X	MG RESISTOR		

BLOCK NO. 02111111				REMARKS	SUFFIX
A	REF.	PARTS NO.	PARTS NAME		
R	843	NRSA02J-182X	MG RESISTOR		
R	846	NRSA02J-511X	MG RESISTOR		
R	847	NRSA02J-122X	MG RESISTOR		
R	848	NRSA02J-152X	MG RESISTOR		
R	849	NRSA02J-222X	MG RESISTOR		
R	850	NRSA02J-222X	MG RESISTOR		
R	851	NRSA02J-513X	MG RESISTOR		
R	852	NRSA02J-684X	MG RESISTOR		
R	853	NRSA02J-103X	MG RESISTOR		
R	854	NRSA02J-103X	MG RESISTOR		
R	855	NRSA02J-103X	MG RESISTOR		
R	856	NRSA02J-103X	MG RESISTOR		
R	857	NRSA02J-103X	MG RESISTOR		
R	858	NRSA02J-271X	MG RESISTOR		
R	870	NRSA02J-511X	MG RESISTOR		
R	873	NRSA02J-591X	MG RESISTOR		
R	874	NRSA02J-591X	MG RESISTOR		
R	875	NRSA02J-271X	MG RESISTOR		
R	876	NRSA02J-271X	MG RESISTOR		
R	877	NRSA02J-511X	MG RESISTOR		
R	878	NRSA02J-511X	MG RESISTOR		
R	879	NRSA02J-271X	MG RESISTOR		
R	880	NRSA02J-271X	MG RESISTOR		
R	881	NRSA02J-511X	MG RESISTOR		
R	882	NRSA02J-511X	MG RESISTOR		
R	883	NRSA02J-511X	MG RESISTOR		
R	884	NRSA02J-511X	MG RESISTOR		
R	885	NRSA02J-591X	MG RESISTOR		
R	886	NRSA02J-591X	MG RESISTOR		
R	887	NRSA02J-271X	MG RESISTOR		
R	888	NRSA02J-271X	MG RESISTOR		
R	889	NRSA02J-681X	MG RESISTOR		
R	890	NRSA02J-681X	MG RESISTOR		
R	891	NRSA02J-681X	MG RESISTOR		
R	892	NRSA02J-681X	MG RESISTOR		
R	893	NRSA02J-101X	MG RESISTOR		
R	895	NRSA02J-102X	MG RESISTOR		
S	851	NSW0124-001X	TACT SWITCH	"5"	
S	852	NSW0124-001X	TACT SWITCH	"6"	
S	853	NSW0124-001X	TACT SWITCH	"DISPLAY"	
S	854	NSW0124-001X	TACT SWITCH	"SCAN"	
S	855	NSW0124-001X	TACT SWITCH	"LOUD"	
S	856	NSW0124-001X	TACT SWITCH	"CD-CH"	
S	857	NSW0124-001X	TACT SWITCH	"TUNER"	
S	858	NSW0124-001X	TACT SWITCH	"CD-CH"	
S	859	NSW0124-001X	TACT SWITCH	"SELECT"	
S	860	NSW0124-001X	TACT SWITCH	"F.SKIP/UP"	
S	861	NSW0124-001X	TACT SWITCH	"1"	
S	862	NSW0124-001X	TACT SWITCH	"2"	
S	863	NSW0124-001X	TACT SWITCH	"3"	
S	864	NSW0124-001X	TACT SWITCH	"4"	
S	865	NSW0124-001X	TACT SWITCH	"EJECT"	
S	866	NSW0124-001X	TACT SWITCH	"POWER"	
S	867	NSW0124-001X	TACT SWITCH	"SOUND"	
S	868	NSW0124-001X	TACT SWITCH	"MD/RND"	

BLOCK NO. 02111111				REMARKS	SUFFIX
A	REF.	PARTS NO.	PARTS NAME		
S	869	NSW0124-001X	TACT SWITCH	"REPEAT"	
S	870	NSW0124-001X	TACT SWITCH	"B.SKIP/DOWN"	



# Packing materials and accessories parts list

Block No. M 3 M M

Block No. M 4 M M

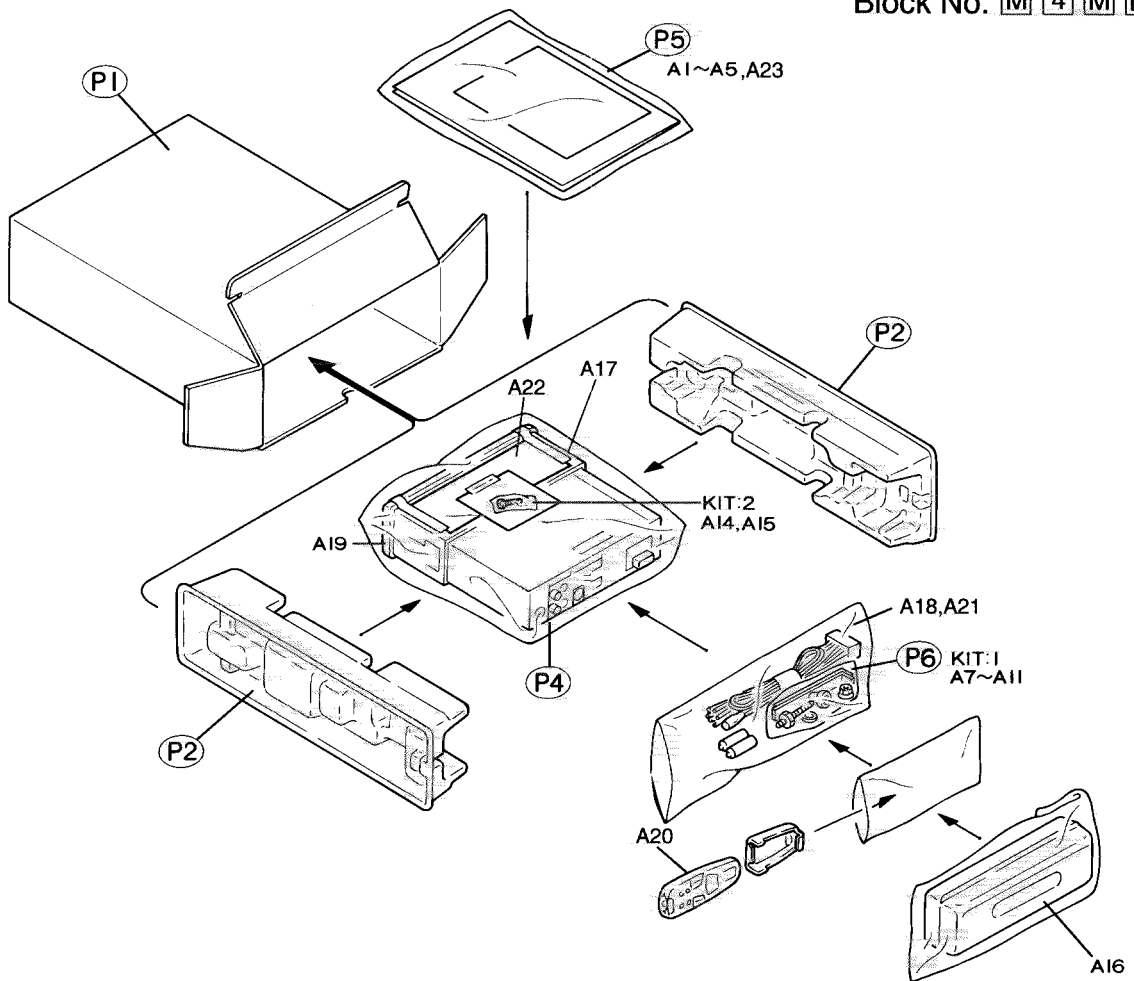

## ■ Packing parts list

BLOCK NO. M 3 M M

REF.	PARTS NO.	PARTS NAME	REMARKS	QTY	SUFFIX	CLR
P 1	FSPE3004-075	PACKING CASE		1		
P 2	FSPH1014-001	PAPER CUSHION		2		
P 4	VPE3005-064	POLY BAG	SET(260X440X0.0	1		
P 5	QPA01703505P	POLY BAG	INST.BOOK	1		
P 6	QPA00801205	POLY BAG		1		

## ■ Accessories parts list

BLOCK NO. M 4 M M

REF.	PARTS NO.	PARTS NAME	REMARKS	QTY	SUFFIX	CLR
A 1	FSUN3103-631	INST.BOOK	ENG,SPA,FRE	1		
A 2	FSUN3103-T631	INSTRUCT.SHEET		1		
A 3	BT-51018-1	WARRANTY CARD	FOR USA ONLY	1		
A 8	BT-52001-4	WARRANTY CARD	FOR CANADA ONLY	1		
A 4	BT-20071B	JVC CENTER LIST	FOR USA ONLY	1		
A 5	BT-51020-2	J-REGIST CARD		1		
A 7	VK24027-202	PLUG NUT		1		
A 8	VKH4871-001SS	MOUNT BOLT		1		
A 9	VK24328-001	LOCK NUT	FOR M5	1		
A 10	WNS5000Z	WASHER		1		
A 11	FSKL4010-002	HOOK		2		
A 14	VK24777-001	MINI SCREW		1		
A 15	FSYA4001-001	SHEET		1		
A 16	FSJB3001-30A	HARD CASE		1		
A 17	FSKM2004-202	MOUNTING SLEEVE		1		
A 18	GAM0013-006	1&P CORD ASS'Y		1		
A 19	FSJD2034-001	TRIM PLATE		1		
A 20	GAL0075-001	REMOCON		1		
A 21	-----	BATTERY		1		
A 22	LV41417-001A	CAUTION		1		
A 23	LVT0326-001C	TROUBLE SHOOTIN		1		
KIT 1	KDGS717K-SCREW1	SCREW PARTS KIT	A7-A11	1		
KIT 2	KDGS727J-SCREW2	SCREW PARTS KIT	A14,A15	1		

**KD-SX650**

**JVC**

VICTOR COMPANY OF JAPAN, LIMITED  
MOBILE ELECTRONICS DIVISION, 10-1, 1Chome, Ohwatari-machi, maebashi-city, Japan

(No.49520)

 Printed in Japan  
9911(O)